



Guidance Technology Options

Outline Business Case - Appendix E

17 January 2020

Mott MacDonald
22 Station Road
Cambridge CB1 2JD
United Kingdom

T +44 (0)1223 463500
mottmac.com

Guidance Technology Options

Outline Business Case - Appendix E

17 January 2020

Issue and Revision Record

Revision	Date	Originator	Checker	Approver	Description
1.0	11.11.2019	S. Luke	C. Searson	J. Baker	Issued for Approval
2.0	17.01.20	S. Luke	C. Searson	J. Baker	Issued for Approval
3.0	17.01.20	S. Luke	C. Searson	J. Baker	Issued for Approval

Document reference: 392438-MMD-BCA-XX-RP-BC-0035 |

Information class: Standard

This document is issued for the party which commissioned it and for specific purposes connected with the above-captioned project only. It should not be relied upon by any other party or used for any other purpose.

We accept no responsibility for the consequences of this document being relied upon by any other party, or being used for any other purpose, or containing any error or omission which is due to an error or omission in data supplied to us by other parties.

This document contains confidential information and proprietary intellectual property. It should not be shown to other parties without consent from us and from the party which commissioned it.

Contents

Executive summary	8
1 Introduction	9
2 Policy Context	10
2.1 Existing Operating Context	10
2.2 The Aim for Cambridge	10
2.3 Operational Requirements	10
2.4 Transport & Works Act Orders (TWAOs)	11
2.5 Aspirations for a future Mass Transit System	11
2.6 Benefits of Guidance	11
2.7 Bus Guidance in the UK Context	11
3 Kerb Guidance	14
3.1 Overview of Kerb Guidance	14
3.2 Benefits of Kerb Guidance	14
3.3 Limitations of Kerb Guidance	14
4 Optical Guidance	15
4.1 Overview of Optical Guidance	15
4.2 Benefits of Optical Guidance	15
4.3 Limitations of Optical Guidance	15
4.4 Examples of Optical Guidance Deployment	15
4.5 Technological Example: Siemens Optiguide, Optiboard and Optilane	16
5 Other Guidance Technologies	19
5.1 Trolley Systems	19
5.2 Slot/Rail Guidance	20
5.3 Magnetic Guidance	22
5.4 Wire/Cable Guidance	24
6 Running Way / Guideway	26
6.1 Kerb Guidance	26
6.2 Other Guidance Systems	29
7 Market Sounding	30
8 Assessment Matrix	31

9	Summary	33
---	---------	----

	Appendices	34
--	------------	----

A.	Market Sounding Advert	35
----	------------------------	----

B.	Trackless Tram (ART)	36
----	----------------------	----

C.	Questionnaire - Siemens	37
----	-------------------------	----

Tables

	Table 8.1: Requirements Assessment	31
--	------------------------------------	----

Figures

	Figure 2.1: UK Guidance Systems Currently in Operation	12
--	--	----

	Figure 2.2: European Guidance Systems Currently in Operation	13
--	--	----

	Figure 4.1: Las Vegas MAX	16
--	---------------------------	----

	Figure 4.2: Illustration of Guidance Technology	17
--	---	----

	Figure 5.1: Nancy	21
--	-------------------	----

	Figure 5.2: Translohr	21
--	-----------------------	----

	Figure 5.3: Phileas Bus	23
--	-------------------------	----

	Figure 5.4: Phileas Bus	23
--	-------------------------	----

	Figure 5.5: STTS vehicles in the channel Tunnel	24
--	---	----

	Figure 5.6: Millennium Dome Busway	25
--	------------------------------------	----

	Figure 6.1: Precast kerb guided busways – Luton-Dunstable busway during construction and testing	26
--	--	----

	Figure 6.2: Slip formed kerb guided busways – Leigh-Salford-Manchester Bus Rapid Transit scheme during construction	27
--	---	----

	Figure 6.3: CRCP kerb guided busways – Bristol Metrobus during construction	28
--	---	----

Executive summary

This document constitutes a paper the purpose of which is to review available guidance technology that could be used on various GCP schemes.

The Scope of Works investigates guidance technology options for new rubber tyred vehicles to operate on the proposed A1307 Phase 2 Strategy 1 corridor and Cambourne to Cambridge scheme and is cognisant of the existing Cambridge Guided Busway (CGB) corridor, and CAM. This may apply to a new fleet of vehicles and/or retrofitting of existing fleet.

Six guidance technology options have been investigated:

- Kerb
- Optical
- Trolley
- Slot/rail
- Magnetic
- Wire/cable

Mott MacDonald, on behalf of the Greater Cambridgeshire Partnership undertook a market sounding exercise in October 2018 to determine market interest and the availability of technological guidance solutions for deployment on the Cambridgeshire Rapid Transit schemes (principally the A428 and A1307 schemes).

Only one response from the market sounding exercise was provided. This was from Siemens who provided details of their Optiboard optical guidance system with examples provided in Rouen, Nimes, Castellon, Bologna and Tokyo.

Both kerb guidance and optical guidance achieve most or all of the guidance requirements for the A1307 scheme and should be developed/investigated further. This should be undertaken in conjunction with the A428 scheme development to enable consistency in the technical solutions.

Trolley systems whilst having international applications, when developed for application in the UK (Leeds New Generation Transit) were not granted powers. Part of the basis of this decision related to the appropriateness of the trolley technology. Trolley solutions would require OHLE which would not be acceptable on C2C.

Slot/Rail guidance has had only limited market penetration and importantly have been developed principally for urban applications with operating speeds of around 50kph.

Magnetic guidance systems have not achieved market penetration.

Wire/cable guided systems have not demonstrated proven passenger operation.

1 Introduction

This document constitutes a paper the purpose of which will be to assist GCP with understanding the range of guidance technology options available that will deliver project objectives.

The Scope of Works investigates guidance technology options for new rubber tyred vehicles to operate on the proposed A1307 Phase 2 Strategy 1 corridor and is cognisant of the existing Cambridge Guided Busway (CGB) corridor, A428 scheme and CAM. This may apply to a new fleet of vehicles and/or retrofitting of existing fleet.

2 Policy Context

2.1 Existing Operating Context

There are two main bus operators in Cambridgeshire, being Stagecoach and Whippet. These two operators run vehicles on the existing kerb-guided busway (The Busway) as well as other on-road routes throughout the county. A small number of other operators run short, rural services in wider Cambridgeshire.

There are also two main bus fleets in Cambridgeshire, being Volvo/Wrightbus and Alexander Dennis/Scania. These are the only fleets to operate on The Busway and this fleet of buses run throughout Cambridgeshire.

The Busway was opened in 2011 and now has six routes. These are:

- A: St Ives – Trumpington.
- B: Peterborough – Cambridge.
- C: St Ives – Cambridge.
- N: Longstanton – Cambridge.
- R: Cambridge – Trumpington.
- U: Addenbrookes Hospital – Eddington.

2.2 The Aim for Cambridge

Following the granting of City Deal funding to improve transport infrastructure in Cambridge, the key aims of a Mass Transit 'Concept' serving the city and wider region are:

- A high quality public transport system using rapid transit technology.
- High frequency, reliable services delivering maximum connectivity.
- Continued modal shift away from car usage to public transport.
- Capacity provided for growth, supporting transit-oriented development.
- Technology used that is not completely new in the first instance and has been proven to work elsewhere.
- Integration with and flexible adaptation to emerging technologies.

This study looks to fit seamlessly with this wider context to identify forms of guidance technology that will enable these key objectives for Cambridge.

2.3 Operational Requirements

The C2C scheme objectives include the following objectives that are relevant to defining the operational requirements for the HQPT system to be delivered by the project:

- Provide **additional capacity** during the peak periods to meet forecasted growth in demand along the A428/A1303.
- Deliver HQPT offering **improved waiting and in-vehicle environments** that are **comparable to Cambridge's existing Guided Busway**.
- Improve the attractiveness of sustainable modes of travel as an alternative to using cars, leading to an increase in their mode share.

The Transport Strategy for Cambridge and South Cambridgeshire (Cambridgeshire CC, 2014) defines a HQPT service as “one that provides, high quality, low floor/easy access buses, air conditioning, prepaid/ electronic ticketing, RTPI and branding to encourage patronage.”

2.4 Aspirations for a future Mass Transit System

The preferred option for a future mass transit system proposed in the Greater Cambridge Mass Transit Options Assessment Report is a concept given the working title of Cambridgeshire Autonomous Metro (CAM). This is an option developed to utilise emerging driverless and connected vehicle technology. The CAM concept also includes tunnelling to deliver an alignment within Cambridge city centre that provides the required journey time reliability and transit capacity.

It is proposed that CAM would operate using bespoke rubber-tyred articulated vehicles, with a capacity of 100 to 250 people. The aspiration is for vehicles offering a level of ride quality equivalent to that of a conventional Light Rapid Transit system, aided by battery-electric propulsion.

This report also identifies the C2C and A1307 scheme routes as integral elements of any future CAM network. It has thus been recognised that the C2C and A1307 projects should be developed in a way which complements and aligns with the CAM aspirations, with the aim of future-proofing the investment made in a HQPT system in advance of aspirations for a wider rapid transit network across Greater Cambridgeshire being realised.

In the context of the emerging CAM proposals and the potential for future tunnelled sections of segregated public transport infrastructure, a single deck articulated bus may be a more appropriate option than a double deck bus to deliver the additional capacity required on the C2C and A1307 systems to meet future growth in demand.

2.5 Benefits of Guidance

Guided systems offer a number advantages over a non-guided. These statements relate to kerb guided busways (but some are also true for other guidance technologies).

- Narrower corridor and reduced land take – guidance means that vehicles can pass closer to each other.
- Self-enforcing – discontinuous pavement and kerb upstands discourage use by unauthorised vehicles.
- Segregated route prevents conflict with other road users or private access.
- Reduced impermeable paved area - incorporation of sustainable drainage systems (SuDS) within the guideway.
- Level boarding and docking at stops.
- A side-guided busway cannot be easily converted into a road – preserves the segregation of the busway against pressure from other road users e.g. taxis, multiple occupancy vehicles.

2.6 Bus Guidance in the UK Context

All UK busways are kerb-guided. Other guidance systems have not yet proven faultless operation. Existing guided busways include those in Cambridgeshire, West Yorkshire, Luton-Dunstable, Leigh-Salford-Manchester and Bristol. These are covered by a variety of operators including First, Stagecoach, Arriva and other independent entities.

Recent UK Bus Rapid Transit projects such as Leigh-Salford-Manchester and Bristol Metrobus have seen operators investing in high capacity double deck vehicles under statutory Quality Partnership Schemes.

There has been little interest in other forms of guidance in the UK up to this point, given the lack of precedence, cost and commercial risk when these schemes were being developed. However, a number of optical guidance systems are in use in Europe, with examples in Rouen, France; Castellon, Spain and Bologna, Italy. With renewed interest in developing technologies such as autonomous vehicles in recent years, it is felt that it would be of benefit considering these alternative forms of guidance.

Figure 2.1: UK Guidance Systems Currently in Operation

UK Guidance Systems

Currently In Operation

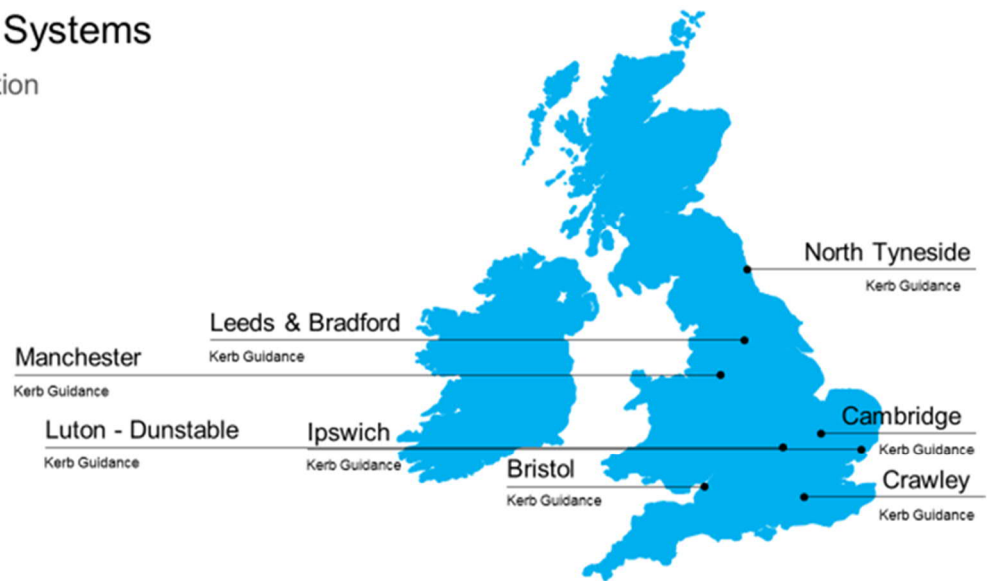

Figure 2.2: European Guidance Systems Currently in Operation



2.6.1 The Cambridgeshire Experience

The Cambridgeshire Guided Busway passed through the 20 million passenger threshold in 2017 (total passenger numbers since opening in 2011) and is currently experiencing annual growth in the order of 4% per year. Surveys undertaken indicated that around a quarter of passengers using the busway had previously driven indicating a strong modal shift from private car to public transport. Passenger satisfaction surveys highlight the strong positive feedback around comfort, reliability, speed and ability to meet the travel needs of users with a more than 90% approval rating in 2017.

3 Kerb Guidance

3.1 Overview of Kerb Guidance

Kerb-guided busway systems all have the following distinct attributes:

- Small horizontal guide wheels fixed to the steering track of buses.
- Horizontal wheels on bus axles make contact with the kerbs, guiding the bus.
- The bus approaches a guided section at low speed, ensuring a smooth entry.
- On the busway the driver only controls the acceleration and braking.
- The width of the busway is determined by the width of the bus and the additional guidewheels.

The Busway has had a positive impact on modal usage in Cambridge with steadily increasing passenger figures, although the city still suffers from severe traffic congestion and air quality issues and an ageing network that requires more alternatives to driving in order to address these challenges.

3.2 Benefits of Kerb Guidance

Benefits of the technology include:

- The guideway allows for high speed operation (over 85 km/h on the existing CGB).
- A narrow guideway takes up less space than a conventional multi-vehicle road (3.2/6.3m as opposed to 3.5/7.3m).
- Allows for precise positioning at boarding platforms, helping those with limited mobility as access can be perfectly level.
- Proven in several cities over a long period both in the UK and further afield.

3.3 Limitations of Kerb Guidance

Limitations of the technology include:

- Must be fully separated from general traffic to use: car drivers can misread signs and get stuck on the busway.
- Guide kerbs with a height of 18cm are required for buses to operate in full guide mode.

Not possible to use a guideway in areas where significant pedestrian desire lines exist that would cross a busway and could not be managed by controlled crossings.

4 Optical Guidance

4.1 Overview of Optical Guidance

Optical guidance systems use the following technology to operate:

- A camera at the front of the vehicle constantly records a defined area, scanning bands of paint on the ground representing a reference path.
- An onboard computer combines signals obtained from a camera with the dynamic parameters of the vehicle to generate commands. Parameters include:
 - Vehicle speed.
 - Yaw rate (turning angle around the vehicle's axis).
 - Steering wheel angle (to detect deviations).
 - Commands are transmitted to the guidance motor on the steering column to correct any deviation of the vehicle from the reference path.

4.2 Benefits of Optical Guidance

Benefits of the technology include:

- Allows for alignment at stops for level boarding.
- Buses can follow a fixed path around corners.
- Technology can be retrofitted to any bus.
- Smooth transition between continuous guidance and no guidance modes.
- Limited fixed infrastructure required.

4.3 Limitations of Optical Guidance

Limitations of the technology include:

- The system currently has a low maximum speed of less than 50 km/h but can potentially operate at 85kph subject to testing and development.
- The system is proprietary.
- A high cost is associated with retrofitting the technology to existing bus fleets.
- Constant wheel tracking can lead to road surface damage. This is implicit on any system that confines a vehicle to a defined path.
- The full road width is required e.g. to accommodate the dynamic kinematic envelope of the vehicle.
- Potential problems with onboard cameras reading the road markings in adverse weather conditions such as snow and ice. Details of performance in adverse weather conditions from the Siemens optical guidance system are included in Appendix C.
- Frequent requirement to repaint road markings.

4.4 Examples of Optical Guidance Deployment

4.4.1 Bus Example: Iveco Crealis Bus

- Includes an option for a built-in optical guidance system for precision docking.

- Complies with the highest European standards of accessibility and mobility.
- Available as a Diesel Euro VI, CNG and Hybrid versions.
- 12.33 metres long, 2.55 metres wide and a capacity of 24. Only articulated buses available so incompatible at this stage.
- Supplied 151 CNG buses to Baku in Azerbaijan in advance of the Pan-European Games in 2015.
- Total sales of approximately 500 buses.

4.4.2 Bus/Tram/Train Example: Autonomous Rapid Transit Train, Zhuzhou, China

- Uses optical guidance to run on virtual tracks marked by white dashes.
- Can reach speeds up to 70km/h.
- Passenger capacity of 300 passengers in 3 modules with an extended 5 module version increasing to 500 passengers.
- Described as a train, tram and bus crossover and began passenger service in 2018.
- Planned to have autonomous capability in the near future¹ with onboard sensors capable of feeding required information to plan its own routes.

4.4.3 Other Examples

Other examples include:

- Solaris Urbos BHNS, France: includes a Siemens Optiguide system integrated into its front.
- Las Vegas MAX, USA: a diesel-electric bus equipped with Siemens Optiguide. The system was eventually removed due to issues with keeping road markings clear of dust and sand.

Figure 4.1: Las Vegas MAX



4.5 Technological Example: Siemens Optiguide, Optiboard and Optilane

Siemens have developed three forms of optical guidance technology, with varying levels of market penetration thus far. These are:

- Optiguide: provides guidance to secure docking of the bus. Examples include the Tokyo 2020 Olympics Rapid Transit System, Las Vegas, Rouen, Nimes and Castellon.

¹ Autonomous public transport vehicles currently do not have approval for operation on the public highway in the UK. The UK's first pilot will include five autonomous single decker buses travelling across the Forth Road Bridge. A driver will still be required to be present on the bus during the trial as a back-up for passenger safety and to comply with UK legislation. The pilot is expected to be operational by 2021

- Optiboard provides assistance to secure docking of the bus with steering effort dependent on speed. Trials are taking place in Bologna, Italy this year.
- Optilane follows lane signalling and is seen as the first step into an Advanced Driver Assistance System. No market examples exist yet, although trials will be taking place in Tokyo in advance of the 2020 Olympics.
- Optiguide can be installed on multiple bus systems up to 24m long vehicles and has shown an accuracy of 1-5mm from platform. The technology can also operate at speeds up to 70kph on a test track and at speeds of 35-40kph when docking. Bus suppliers who are currently using this technology include Renault, Solaris and Scania.

Figure 4.2: Illustration of Guidance Technology

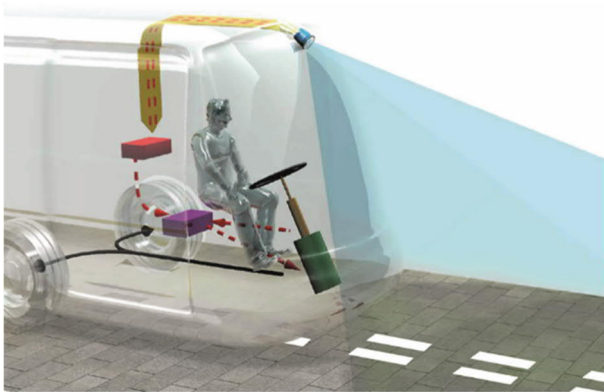

4.5.1 Case Study: 2020 Tokyo Olympics

- Siemens Optiguide technology used within an Advanced Rapid Transit System to meet the challenges caused by urban growth and aging population.
- Aiming to create a stress-free transportation network during the Games with a similar system expanded to other cities in the country.
- Fulfilling the three priorities of social impact, Games hospitality and shared value.
- Developments to be trialled include precise docking control, acceleration control, public transportation priority and whole system integration.
- To operate on the Toyota 'Sora' Fuel Cell Bus.

4.5.2 Our View of the Technology

Based on our research, our view of this technology is generally positive for the following reasons:

- There is evidence of successful deployments and market penetration in various locations.
- The technology can be installed on a range of buses.
- The technology is new and a first in the UK but has been proven to work.
- Discussions are already underway between Siemens and selective UK bus suppliers.
- The docking system has demonstrated a potential accuracy of 1-5mm.

However, there is a need to be cautious as:

- There is a requirement for system integration with particular bus models.
- Any ability to retrofit is dependent on an ability to enable system integration.

Nevertheless, there is certainly the potential for further examination of this technology for deployment in Cambridge.

5 Other Guidance Technologies

A number of other guidance technologies have been developed in Europe, with marginal success in market.

deployment. These include:

- Trolley Systems – Widely used, and historically proven in the UK, for example in Arnhem, NL.
- Slot/Rail Guidance – Example in Caen, France.
- Magnetic Guidance – Example in Eindhoven, Netherlands.
- Wire/cable Guidance – Example of service vehicles in the Channel Tunnel.

However, there are a number of issues with these technologies, including:

- They are all low speed, with a general maximum of 50kph.
- They are often expensive from fleet procurement, associated infrastructure and maintenance perspectives.
- They are largely unproven with negligible market take-up.
- Purpose built vehicles are required with manufacturer-specific systems.

5.1 Trolley Systems

The trolleybus (variously known as 'trolley-coach', 'tbus', 'electroliner', 'street car' or 'trackless tram') is a bus that is powered by electricity from two overhead wires - though it could also be viewed as a tram with rubber tyres instead of metal wheels and track.

Traditionally trolleybuses were introduced because of their operational performance, energy efficiency and reliability, and widely used including in the UK, although they were replaced by diesel buses in some locations, including the UK, as fuel costs dropped in 1950's and diesel engines became more reliable.

Environmental considerations have been one of the main drivers behind renewed interest in trolleybus systems, providing similar levels of operational flexibility as conventional bus systems. Trolleybus has a particular role in citywide systems providing economies of scale in operation and where there are high requirements on environmental objectives.

The modern trolleybus has the potential to offer a prestigious, affordable mode of transport which, in a well-designed scheme, will have a 'more than the sum of its parts' reward in terms of passenger numbers, passenger satisfaction and thus profitability.

Standard trolleybuses can move round obstacles such as parked cars or run off the wires for short distances using auxiliary power units [APU's] typically using batteries and can automatically lower the trolley booms enabling the vehicle to continue 'off wire' without stopping. Automatic rewiring can be achieved with 'pans' fitted to the overhead at appropriate locations. The most popular choice of APU is a 50kW to 75kW diesel alternator unit, permitting operation at up to 15 to 20 MPH.

Alternative battery or flywheel APUs have the advantage of ensuring zero emissions at all times but performance and/or range are more limited.

Modern dual mode trolleybuses can be as flexible in operation as conventional buses, running without wires, in historic city centres or if there are diversions from the wired routes. Thus, only parts of routes need to be electrified and the trolleybuses can operate in battery (or biofuel) mode at the centre of the routes, as happens in Rome and Beijing.

5.1.1 Leeds New Generation Transit

This system was presented to the TWA Order Unit of the DfT who confirmed the view that OLE did qualify as guidance and that is now preceded by the NGT Order application as it was the only form of guidance on the system.

The Statement of Matters says:

2.9. The Promoters consider that the use of Transport and Works Act (TWA) Order powers offer the best approach to the successful implementation of NGT as TWA Order powers incorporate all necessary legal authorisations and appropriate operational powers through a single consents process.

2.10. The powers listed below are sought by way of the Leeds Trolley Vehicle System Order using the provisions of the Transport and Works Act 1992, an associated application for deemed planning consent under section 90(2A) of the Town and Country Planning Act 1990 and by way of contemporaneous applications for Listed Building and Conservation Area Consents.

2.11. NGT will lead the UK in the reintroduction of trolley vehicles. If the TWA Order is granted by the Secretary of State, this will be the first trolley vehicle system to be secured through powers. TWA Orders expressly contemplate trolley vehicle schemes and in many respects the TWA Order will be similar to those Orders already granted for light rail (tram) schemes in various parts of the country.

5.2 Slot/Rail Guidance

The two principal manufacturers are Bombardier and Lohr Industries (Translohr). GLT systems have been asked to provide a cheaper alternative to light rail in a number of French and Italian towns and cities, including Caen² and Nancy (Bombardier system, Clermont-Ferrand, Padua, and Pisa (Translohr). However, the systems are nevertheless expensive, with the bespoke vehicle costs comparable to a light rail vehicle of similar capacity and significant costs involved in installing the guidance system and overhead lines.

² The system in Caen is understood to be replaced by Light Rail (opening in 2019)

Figure 5.1: Nancy



From our recent discussions with Bombardier, we understand that, in view of the ongoing technical difficulties and high operating costs associated with the existing systems, Bombardier are extremely reluctant to offer this system to any further cities. They are not developing any alternative bus-based systems of this nature as they are positioning themselves to be predominately a LRV manufacturer. The Caen system is reported to be converting to LRT.

The prototype Translohr was unveiled in mid- 2000 and may best be described as looking like a light rail vehicle but running on road with rubber tyres. It is mechanically guided via a central guiding rail, with a pair of centre-mounted wheels beneath the vehicle, running against the guide rail. These wheels are set at a 45o angle to prevent the vehicle from jumping out of the guidance system. Because it has steel wheels running on a centre rail, the overhead wiring the vehicle can operate 'off-line' under battery (or other) traction and can be manually steered.

Figure 5.2: Translohr



Compared with light rail, track construction could be considerably cheaper and faster. The guide track does not need to support the full weight of the vehicle. Since the guide rail automatically guides the vehicle along its route, there are minimal steering controls in the driver's cab. Accelerating and braking are the only functions the driver controls. The Translohr vehicle varies in length from 18m to 39m and can carry between 2,000 to 5,000 passengers per hour depending on the number of modules chosen and the service frequency.

The first example of Translohr opened in Clermont-Ferrand, France in 2005. The scheme reportedly cost £80m of which approximately £55m is attributable to the dedicated traffic lane. Each vehicle is said to cost £1.2m with the overall system costing approx £3.9m per km. Translohr has also been selected by the authorities in Padua, Aquila and on the Mestre-Venice corridor which are all in Italy. There are also applications in Colombia and China.

Because the Translohr vehicle is a proprietary product, there may be restrictions on the scope for other suppliers to provide subsequent vehicle orders. This may have an adverse cost impact. The guidance technology is not approved for UK operation and it is envisaged that extensive trials would be required before adoption in the UK.

In summary:

Slot/Rail guidance systems have the following characteristics:

- Consists of a centralised slot installed within the carriageway.
- Systems include Bombardier's Guided Light Transit system and the Translohr system
 - Translohr is a bidirectional tramway on tyres developed by Lohr Industrie of France.
- Advantages of a guided system and vehicles with tyres.
- Guidance system is provided by two V-shaped rollers tilted at 45 degrees.
- Rubber traction helps provide better grip for improved braking and operation on gradients and tight turning radii.

5.2.1 Benefits of Slot/Rail Guidance

Benefits of the technology include:

- The system benefits from providing a fixed path around corners.
- Can be used in mixed traffic.
- Allows for alignment at stops in the same way as guided bus systems.

5.2.2 Limitations of Slot/Rail Guidance

Limitations of the technology include:

- The system is low speed, usually limited to 50 km/h.
- Constant wheel tracking is likely to cause damage to the road surface over time which is a feature of any guided system that constrains the vehicle path.
- The technology requires purpose-built vehicles with manufacturer-specific systems.
- The switch between guided and non-guided modes is complex.
- Costs are similar and sometimes greater than that of light rail.

5.3 Magnetic Guidance

5.3.1 Overview of Magnetic Guidance

Magnetic Guidance systems have the following characteristics:

- An onboard computer stores the optimal alignment of magnetic beacons embedded within the road surface.
- The vehicle position is checked against that of the magnetic beacons.
- Any deviations are corrected with commands to the steering.

5.3.2 Benefits of Magnetic Guidance

Benefits of the technology include:

- Allows for alignment at stops for level boarding of passengers.
- The vehicle path around corners is fixed.

- Allows for vehicles to move at a sharp angle into stops.
- Can be used in mixed traffic.
- Not affected by adverse weather conditions such as snow and ice.

5.3.3 Limitations of Magnetic Guidance

- Low to medium speed system at less than 65 km/h maximum.
- System still under development.
- The full road width is required for operation.
- Implementations require an expensive vehicle.
- Constant wheel tracking can damage the road surface.

5.3.4 Case Study: Phileas Bus; Eindhoven, Netherlands

- Free Ranging on Grid (FROG) magnetic guidance system used to steer all wheels.
- Uses electronic maps with pre-programmed routes, with distance and direction travelled calculated by counting wheel revolutions and steering wheel angle.
- System allows for 'precision docking' as well as speed control.
- LPG-powered combustion engine and a final electric drive.
- System eventually abandoned due to navigation technology not being robust enough.

Figure 5.3: Phileas Bus



Figure 5.4: Phileas Bus



5.4 Wire/Cable Guidance

5.4.1 Overview of Wire Guidance

Wire Guidance systems have the following characteristics:

- Low level current running through cables embedded below the road surface emit a magnetic field.
- The cable is powered by transmitters located at set intervals (usually 2-3 miles apart).
- The magnetic field is detected by an antenna located under the front of the bus.
- An onboard computer controls the steering via hydraulics.

5.4.2 Benefits of Wire Guidance

Benefits of the technology include:

- Allows for alignment at stops allowing level boarding.
- Can be used in mixed traffic.
- Not affected by adverse weather conditions such as snow and ice.
- The vehicle path around corners is fixed.

5.4.3 Limitations of Wire Guidance

- No successful on-road systems.
- Requirement to bury cable in the road surface has cost implications and vulnerability to being damaged.
- Prone to interference from stray electromagnetic radiation.

5.4.4 Case Study: Service Tunnel Transport System (STTS) Vehicles, Channel Tunnel

- Designed to carry services personnel, emergency services personnel and customs officials.
- Wire guidance was chosen as the best solution for working in a very restricted space within the Channel Tunnel.
- Traction power provided by a 5 cylinder, 3 litre engine as battery power was deemed insufficient due to the length of the tunnel.

Figure 5.5: STTS vehicles in the channel Tunnel



5.4.5 Case Study: Millennium Dome Busway; London, UK

- Wire guidance busway was set to form a part of a highway network due to serve the Millennium Dome.
- A two-cable, self-steering wire guidance system was installed on a 0.8-mile section of busway.
- Was seen as a high-profile Government-sponsored BRT system.
- Wire guidance chosen to allow the passing of broken down vehicles and automatic docking at bus stops.
- The wire guidance system experienced technical difficulties associated with the ability to deliver the necessary lateral control of vehicular movement at full operating speed. The route was instead used by conventional buses.

Figure 5.6: Millennium Dome Busway



6 Running Way / Guideway

6.1 Kerb Guidance

Kerb guided busways have specific infrastructure requirements for the guideway to achieve lateral control of the vehicle.

There are three main construction methods discussed in this document are pre-casting, slip forming and Continually Reinforced Concrete Pavement. The key advantages and disadvantages of these approaches are discussed in context of a guided busway system

6.1.1 Precast

Pre-casting involves the off-site construction of design features (typically using concrete), which are then installed on site to form the design solution. For kerb guided busways this typically involves the pre-casting of 'L'-shaped concrete sections which include the running surface for the bus tyres, with an integrated kerb upstand for guidance purposes. Two of these 'L'-shaped sections are required to form a single busway corridor, supporting and guiding the left and right sides of the bus, typically with a void between them to minimise construction materials and to allow some native planting to minimise the visual impact of the scheme and collect rainwater. For the kerb guided busways constructed in the UK to-date, the length of the precast units has varied between 6m (Luton-Dunstable busway) and 15m (Cambridge busway). These precast units are supported either by other precast units, such as concrete sleepers, or by cast in-situ concrete pad foundations, which also help to maintain the distance between the units.

Figure 6.1: Precast kerb guided busways – Luton-Dunstable busway during construction and testing



The key advantages of precast units for kerb guided busways are:

- It can reduce the amount of labour and time required on-site for installation compared to in-situ construction.

- The construction quality and surface finishing (which affects ride quality and noise production) can be better regulated in the controlled environment of the off-site manufacturing facility.
- The units can be lifted to allow future access, for example to any statutory undertaker's equipment passing underneath.

The key disadvantages are:

- The precast units require transporting to site.
- The frequent and regular spaced joints between the units can cause noise and vibration for both passengers and nearby residents.
- Curved units (both horizontal and vertical) can be expensive to fabricate as it requires the production of construction formwork.

6.1.2 Slip Form

Slip forming is the in-situ construction of design features, using mechanical methods to extrude a long or continuous design solution. For kerb guided busways this typically involves the extruding of a concrete 'U'-shaped channel, which includes the running surface for the bus tyres, with an integrated kerb upstand for guidance purposes, similar to the precast units. Unlike the precast units, the slip formed channel includes a continuous central section, but this may be reduced in construction depth to minimise construction materials and may be overlaid with native planting to minimise the visual impact.

Figure 6.2: Slip formed kerb guided busways – Leigh-Salford-Manchester Bus Rapid Transit scheme during construction



The key advantages of slip formed units for kerb guided busways are:

- The joints between units are less frequent than precast units, typically 250-300m apart. This improves the ride quality and reduces the noise and vibration for passengers and nearby residents;
- Curved layouts (both horizontal and vertical) can be accommodated by the slip forming machinery;
- Reduced impact of differential settlement.

The key disadvantages are:

- There is less control on construction quality and surface finishing. The slip forming machinery creates a smooth surface, which may require a texture applying quickly after slip-forming to aid bus tyre traction/ skid resistance.
- Increased volume of materials compared to precast units.
- Requires specialist construction equipment and operatives.

6.1.3 Continually Reinforced Concrete Pavement

Continually Reinforced Concrete Pavement (CRCP) is an in-situ construction method where a formwork is produced, steel reinforcement is laid and then concrete is poured to form a long or continuous concrete pavement. This construction methodology is often referred to as 'traditional' construction. To provide the kerb guidance, traditional highway kerbs are installed alongside the concrete pavement, or metal guide profiles are attached to the concrete pavement, either for transition locations or the whole of the busway.

Figure 6.3: CRCP kerb guided busways – Bristol Metrobus during construction



The key advantages of CRCP designs for kerb guided busways are:

- Similar to slip forming, in that curves can easily be accommodated, joints are infrequent and differential settlement is reduced.
- Long established highway pavement construction methodology (with exception to the metal profiles), with a large number of contractors and widely available construction machinery.
- Texture can be applied during construction to improve skid resistance.

The key disadvantages are:

- Similar to slip forming, there is less control on construction quality due to the work being undertaken in less controllable environmental conditions.
- More difficult to achieve gauge tolerance between the kerbs/metal guide profiles, resulting in increased labour to install, or reduced ride quality for passengers.
- Traditional highway kerbs may move relative to the trackform, resulting in increased maintenance costs and potential network disruption for planned maintenance periods.

6.2 Other Guidance Systems

Optical guidance systems are typically deployed on standard asphalt road surfacing. However higher specification pavement construction would be required (to avoid channelisation of the surface as the vehicles follow the same path as it follows the line). The design parameters for optical guidance would be expected to be closely aligned to commonly understood road construction guidance and regulations e.g. Department for Transport DRMB.

Slot/rail guidance requires the installation of the guidance within an asphalt pavement with a concrete support system. As above a higher specification pavement construction would be required.

Magnetic and wire/cable systems are not known to require any unique infrastructure other than higher specification pavement construction.

7 Market Sounding

Mott MacDonald, on behalf of the Greater Cambridgeshire Partnership undertook a market sounding exercise in October 2018 to determine market interest and the availability of technological guidance solutions for deployment on the Cambridgeshire Rapid Transit schemes (principally the A428 and A1307 schemes).

Adverts were placed in Trade Press:

- Bus and Coach Weekly (2 editions)
- Local Transport Today
- Passenger Transport Today

In addition, Mott MacDonald followed up at Euro Bus Trade Expo at National Exhibition Centre in Birmingham in October 2018 and raised the market sounding with representatives of major bus suppliers:

- Pelican Yutang
- Scania
- Mercedes Benz
- Optare
- Irizar
- Van Hool
- Wright Bus
- Alexander Denis
- Volvo
- MAN

Only one response from the market sounding exercise was provided. This was from Siemens who provided details of their Optiboard optical guidance system with examples provided in Rouen, Nimes, Castellon, Bologna and Tokyo. This is provided in Appendix C.

8 Assessment Matrix

The six guidance options discussed above have been assessed against requirements for the A1307 scheme; namely:

- Proven full scale passenger operation.
- Ride quality.
- Ability to achieve 90kph operating speed.
- Ability to achieve 70kph operating speed.
- Market uptake.
- Product support.
- Future proofing.
- Compatibility with CAM.
- Approvals (Planning and Operational).

Table 1 provides a summary of the requirements assessment.

Table 8.1: Requirements Assessment

Attribute	Kerb	Optical	Trolley	Slot/Rail	Magnetic	Cable/wire
Full scale passenger operation	Yes	Yes	Yes	Yes	Limited	No
Ride Quality	Good	Good	Good	Good	Unknown	Poor
Achievement of 90kph operating speed	Yes	No	No	No	No	No
Achievement of 70 kph operating speed	Yes	Yes	Yes	No	No	No
Market uptake	Several UK applications	Several international applications	International applications	Limited international applications	No	No
Product Support	High	Good but single supplier	High	Good but limited suppliers	No	No
Future Proofing	Limited due to need to retrofit guideway	Good	Low	Low	No	No
Compatibility with CAM	Yes	Yes	Unknown	No	No	No
Approvals (Planning and Operation)	Good	Good	No	Good	No	No

Both kerb guidance and optical guidance achieve most or all of the guidance requirements for the A1307 scheme and should be developed/investigated further.

Trolley systems whilst having international applications, when developed for application in the UK (Leeds New Generation Transit) were not granted powers. Part of the basis of this decision related to the appropriateness of the trolley technology.

Slot/Rail guidance has had only limited market penetration and importantly have been developed principally for urban applications with operating speeds of around 50kph.

Magnetic guidance systems have not achieved market penetration

Wire/cable guided systems have not demonstrated proven passenger operation.

9 Summary

Six guidance technology options have been investigated:

- Kerb
- Optical
- Trolley
- Slot/rail
- Magnetic
- Wire/cable

Mott MacDonald, on behalf of the Greater Cambridgeshire Partnership undertook a market sounding exercise in October 2018 to determine market interest and the availability of technological guidance solutions for deployment on the Cambridgeshire Rapid Transit schemes (principally the A428 and A1307 schemes).

Only one response from the market sounding exercise was provided. This was from Siemens who provided details of their Optiboard optical guidance system with examples provided in Rouen, Nimes, Castellon, Bologna and Tokyo.

Both kerb guidance and optical guidance achieve most or all of the guidance requirements for the A1307 scheme and should be developed/investigated further. This should be undertaken in conjunction with the A428 scheme development to enable consistency in the technical solutions.

Trolley systems whilst having international applications, when developed for application in the UK (Leeds New Generation Transit) were not granted powers. Part of the basis of this decision related to the appropriateness of the trolley technology.

Slot/Rail guidance has had only limited market penetration and importantly have been developed principally for urban applications with operating speeds of around 50kph.

Magnetic guidance systems have not achieved market penetration.

Wire/cable guided systems have not demonstrated proven passenger operation.

Appendices

A.	Market Sounding Advert	35
B.	Trackless Tram (ART)	36
C.	Questionnaire - Siemens	37

A. Market Sounding Advert

Call for Technologies: Technological Guidance for Passenger Transport Vehicles

Mott MacDonald, on behalf of the Greater Cambridge Partnership, wish to assess the development of advanced technological guidance solutions for Passenger Transport Vehicles for potential adoption as part of the Greater Cambridge Partnership programme of public transport infrastructure rapid transit schemes and the aspirations for a wider rapid transit network across Greater Cambridge.

<https://www.greatercambridge.org.uk/>

Any suppliers of guidance technology or those with vehicles including guidance technology either in full scale passenger operation or with the demonstrated ability to be in full scale passenger operation should contact Stephen Luke for details by phone (+44 (0)1619890401) or email (Stephen.Luke@mottmac.com) to obtain a market sounding questionnaire.

Suppliers responding to the questionnaire will be invited to a supplier information day to be held in Cambridge.

B. Trackless Tram (ART)



Autonomous-rail Rapid Transit 智能轨道快运系统

.crrcgc.cc

 CRRC ZHUZHOU INSTITUTE CO., LTD.

1.

BACKGROUND 背景



- **The expansion of city and growth of population for unrestricted mobility brings the increased traffic volume. People request to develop a safe, punctual and comfortable public traffic system.** 城市的不断扩展和流动人口的增长带动了交通负荷增长，人们迫切要求发展安全，准时和舒适的公共交通系统。
- **Due to the advantages of huge capacity, rapid, punctuality, safety, and comfort, the rail traffic system becomes the important part of city transportation.** 基于高运量，快速，准时，安全，舒适等特点，轨道交通成了城市运输系统的一个重要组成部分。
- **Meanwhile, more and more cities give up the building plan of rail traffic system because of its high investment, long construction period and less flexibility.** 同时，越来越多的城市因为轨道交通系统的大投入，长施工周期和不够灵活而放弃了建设计划。



has the advantages of both tram: huge volume, energy saving and environmental protection and traditional bus: flexible operation. ART结合了有轨电车（大运量，节能和环保）及传统巴士（灵活运营）的优点。

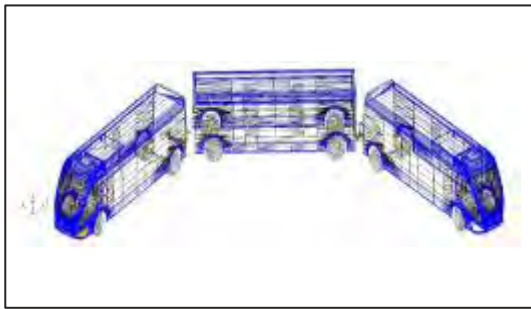

2013开始理论研究
theoretical research



2014年构建实验模型
modeling prototype



2015年构建原型样机
principle prototype



2016年构建工程样机
engineering prototype

2. ART INTRODUCTION 介绍



- The system consists of the tram and the operation management system. ART系统由有轨电车和运营管理系统组成。
- The tram is a multiple units, bidirectional, and 100% low floor vehicle. specially, the all wheel steering control technology is applied, making the tram tracking the virtual rail and running with a rail like mode. ART车辆是一个多动力，双向，100%低地板的车辆，同时使用了车轮转向控制技术以确保车辆跟随虚拟轨道实现驱轨运行模式。
- Based on 2G and 2G wireless communication, the operation management system makes the tram operation in an high efficient and safe way. 基于V2V和V2G无线通信，运营管理系统可以确保车辆始终保持高效和安全的运行。



Signal System
道口信号系统



Station
车站



Tramcar
车辆



Rail
物理轨道



Operational
Management
System
运营管理系统



Inspection
Center
检修中心



Signal System
道口信号系统



Station
车站



ART
智能车辆



Virtual Rail
虚拟轨道



Operational
Management
System
运营管理系统



Inspection
Center
检修中心



Three Cars ART 三模块列车

车长 length	31.6 m
车宽 width	2.6 m
满载车重 vehicle load	8 ton
最大载客人数 total capacity (8 persons/m ²)	307 person
最高车速 Max. speed	70 km/h
最大爬坡能力 Max. ramp slope	13
最小转弯半径 Min. radius of turning circle	1 m
地板高度 height of floor	330mm 100 low floor



ART TECHNOLOGY 主要技术

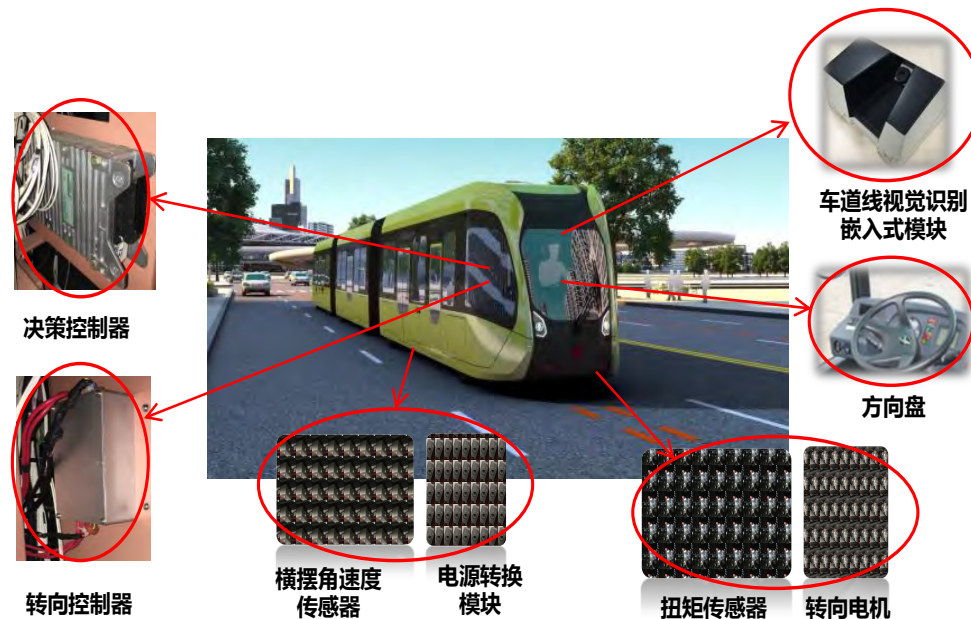
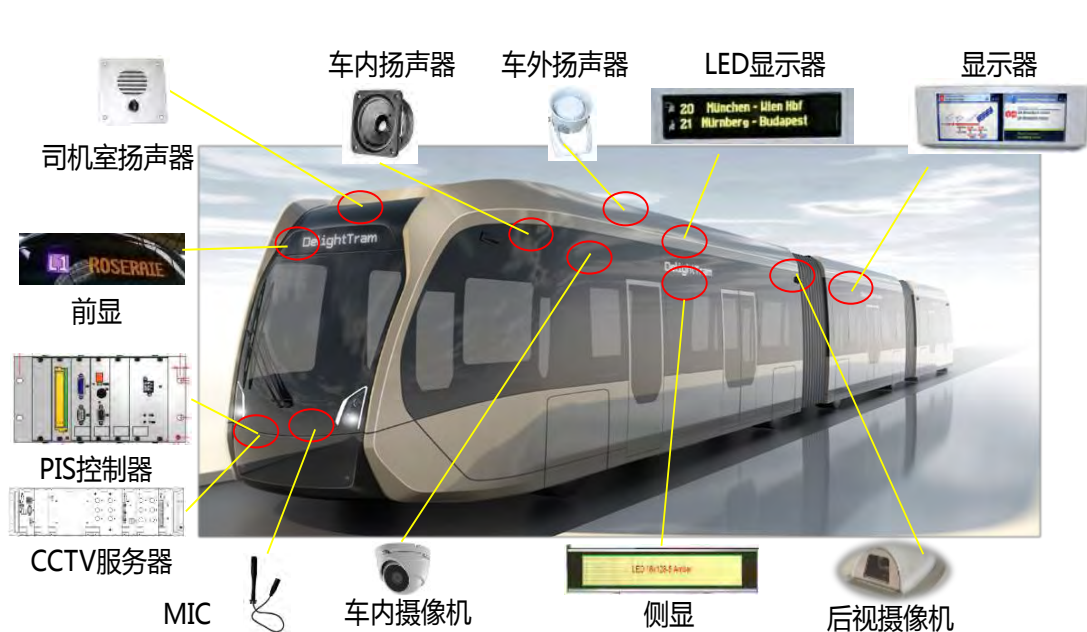

- Using the all wheel steering technique to make the tram track the virtual rail, and run with a rail like mode
使用全轮转向技术以使车辆跟随虚拟轨道实现驱轨模式
- Dual redundant hydraulic system to guarantee the reliability and safety of steering
设置冗余的液压系统以确保转向的可靠性和安全性

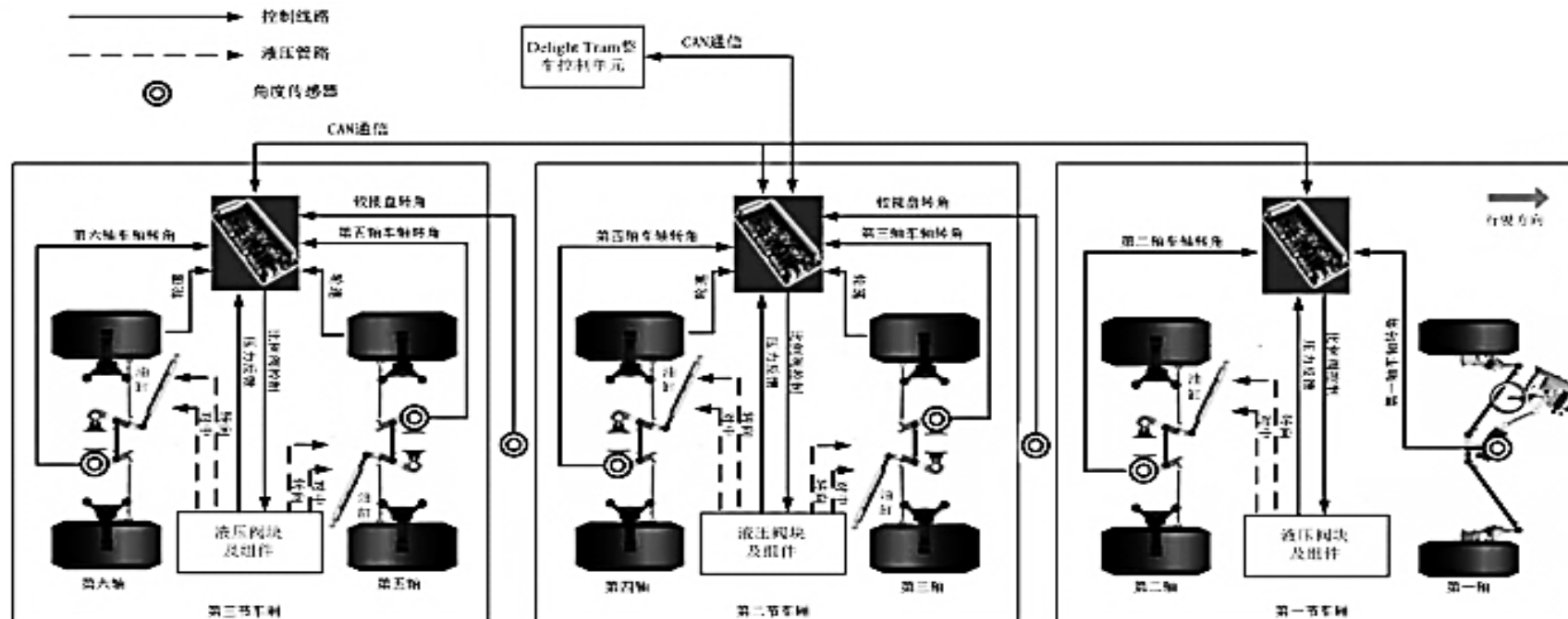

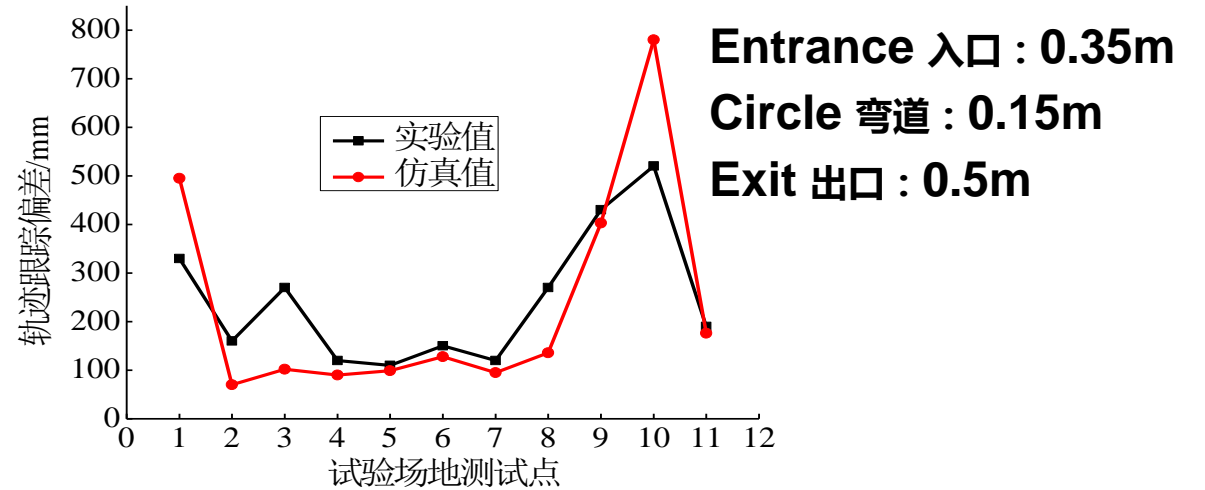
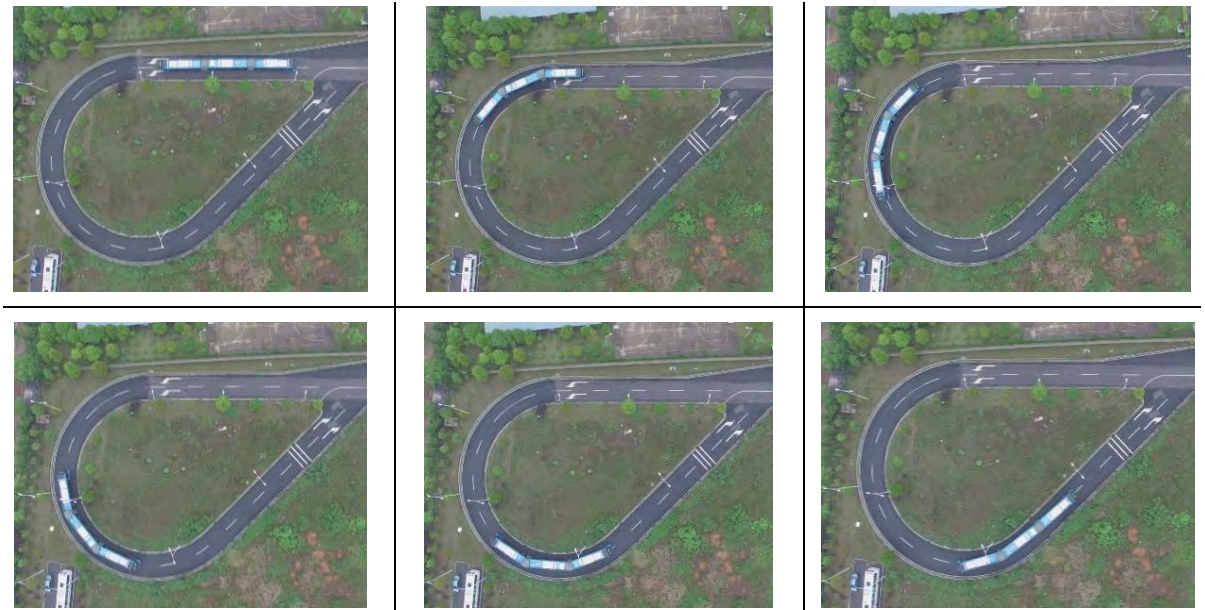
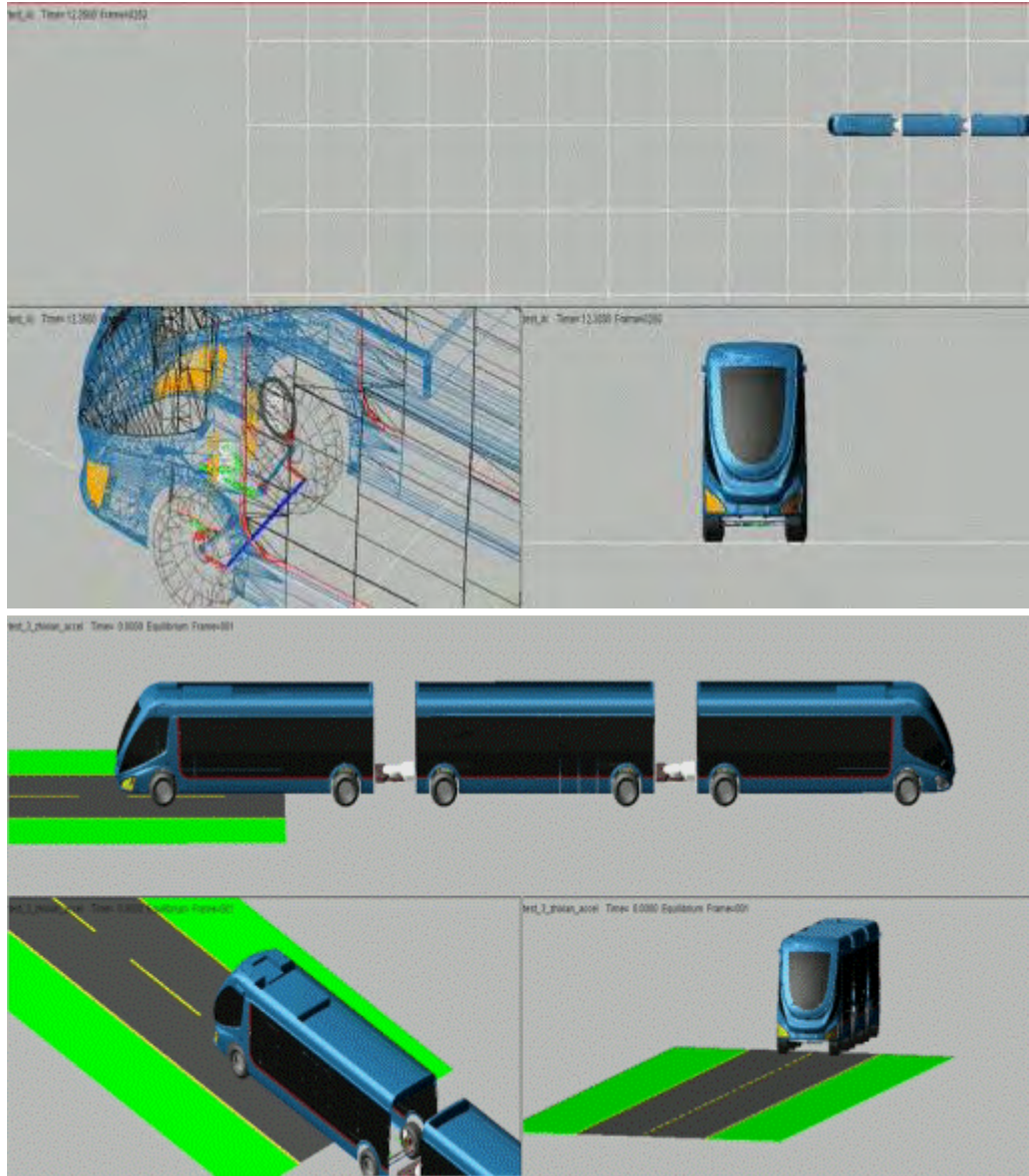

lateral tracking error in test and simulation 横向循迹误差



R SHAPE TESTING TRACK
R形测试场地



8 SHAPE TESTING TRACK
8形测试场地

- **Stage 1 MANUAL DRIVE** : the driver operates the steering wheel and tracks virtual rail lines.
阶段1 手动驾驶：司机操控方向盘，通过眼睛识别轨迹驾驶
- **Stage 2 ADAS** : based on image recognition, vehicle ground communications, steering wire technology.
阶段2 ADAS：基于图像识别，车地通信及线控转向技术
- **Stage 3 AUTOPILOT** : based on the vision, radar, laser and other perceptual integration to realized the vehicle longitudinal and vertical control.
阶段3 自动驾驶：基于视觉，雷达，镭射和其他感知的集成来实现车辆纵向和垂向的控制



ADAS SYSTEM
ADAS系统



Virtual rail detection
虚拟轨道检测



Automatic steering
自动操纵

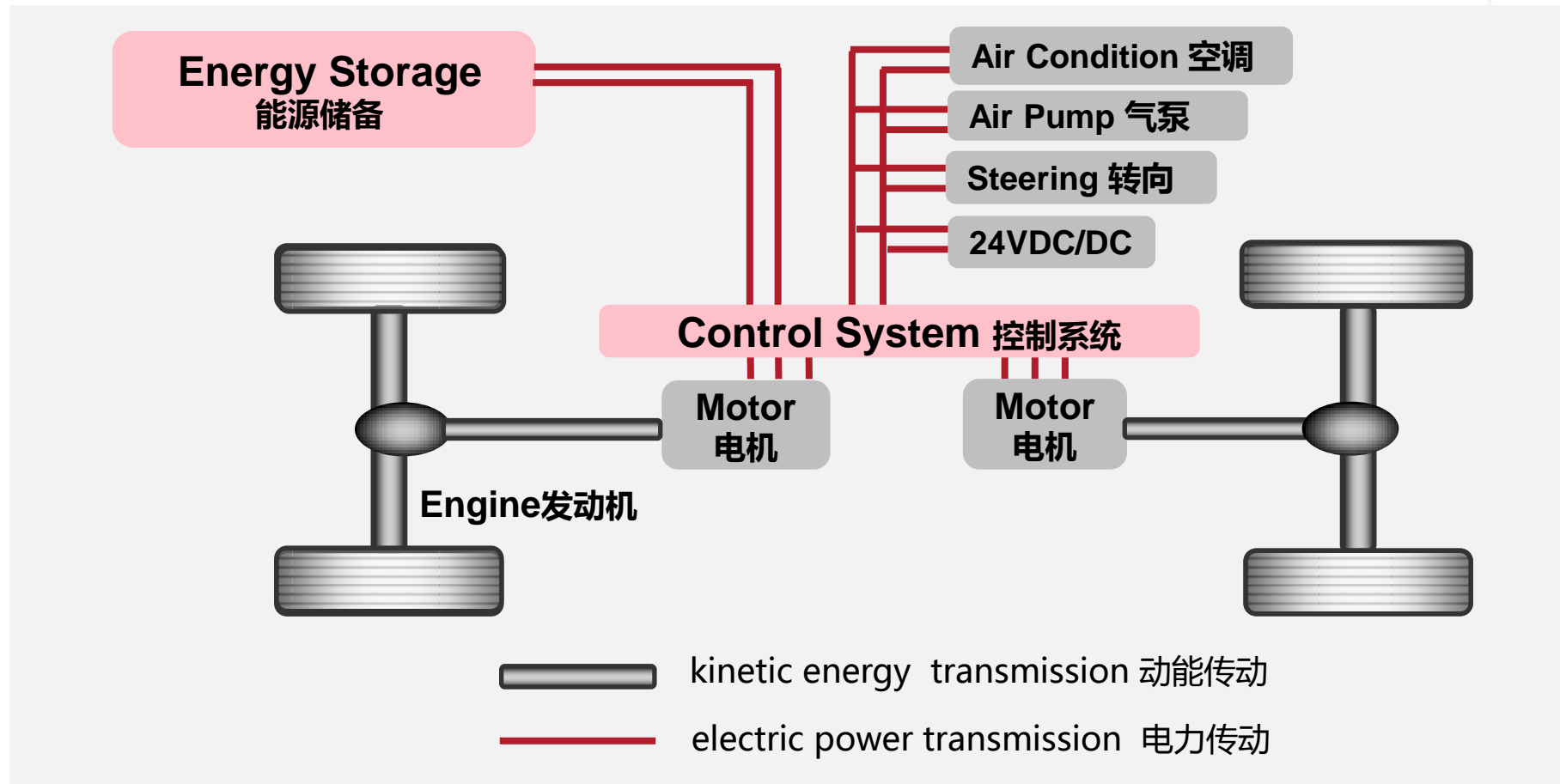

- 4th generation electric power driving system 第四代电传动系统
- permanent magnet motor with high efficiency, small size and light weight 高效，小尺寸和轻量的永磁电机
- Dual stepless speed motor with higher comfort 高舒适的双无极调速电机

MULTI-MODES CHARGING 多种充电模式

- **Fast Charge in Start / End Stations** 在起始站快速充电
- **Once charging in 10 minute, full-load Endurance mileage is 25 km** 充电10分钟可满载运行25 km
- **Supports multi-modes of electrical reception** 支持多种充电模式

Battery 电池

Pantograph 受电弓

Super capacitor 超级电容

- **Base on the length of route, adjust the battery capacity to fit the endurance mileage** 基于路线长度调整电池容量来适应续航里程
- **Flexible endurance mileage** 灵活的续航里程

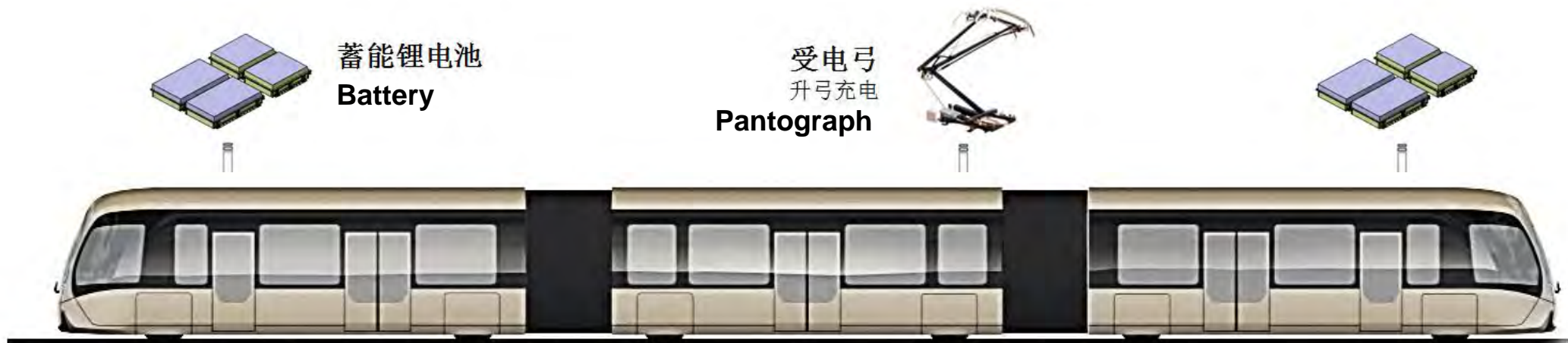

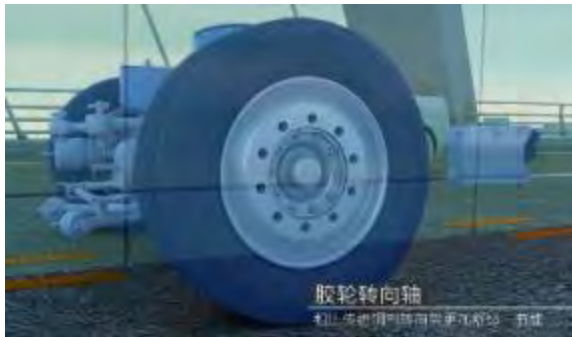

customized tires with good bearing and safety performance
定制轮胎，具有良好的承重和安全性能

- quiet vehicle operation 安静的车辆运营
- Strong capability for climbing the ridges and ramps 强劲的爬坡能力
- superior ride with higher comfort 胶轮提升舒适度
- Maximum deceleration $> 3.3 \text{ m/s}^2$ 最大减速度 $> 3.3 \text{ m/s}^2$



- Light weight design 轻量化设计
- Reliability of the strength of tram frame 车架强度可靠性
- Carbon fiber and aluminum alloy are used in the tram body and cabin 车体和驾驶室使用碳纤维和铝合金
- Design life is **25 years** 设计寿命长达25年

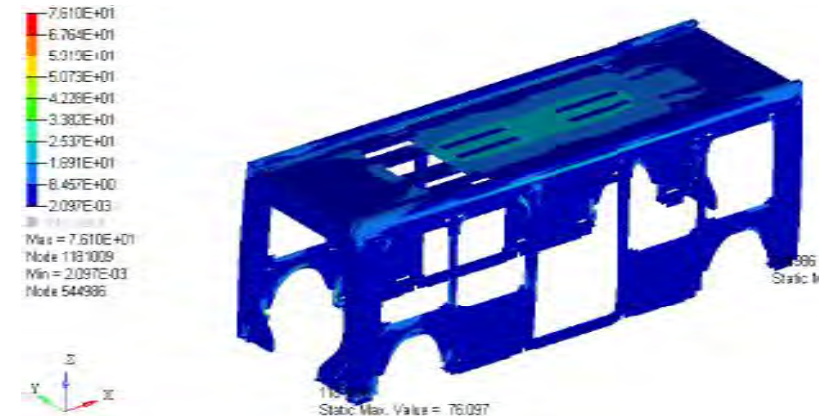
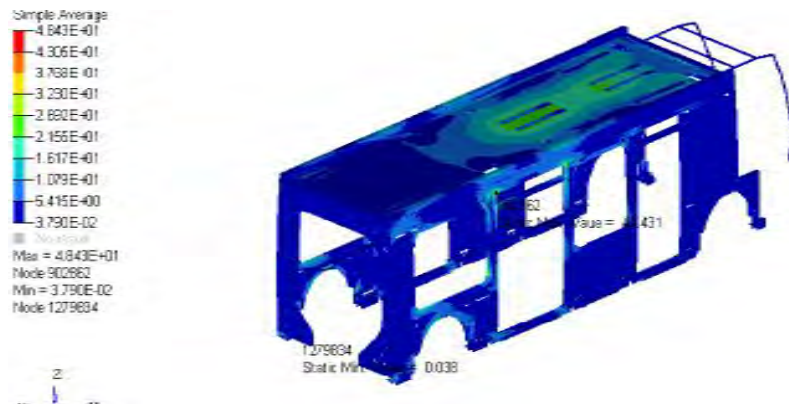



- applying the low floor design with the width of corridor more than 1 m
应用了走廊宽度超过1米的低地板设计
- adding the disabled area and the special seats for pregnant women and children
设有残疾人区域及孕妇儿童专用座椅

The shapes of the cab and the painting are customizable

车辆的外形和色彩可根据城市文化需求定制

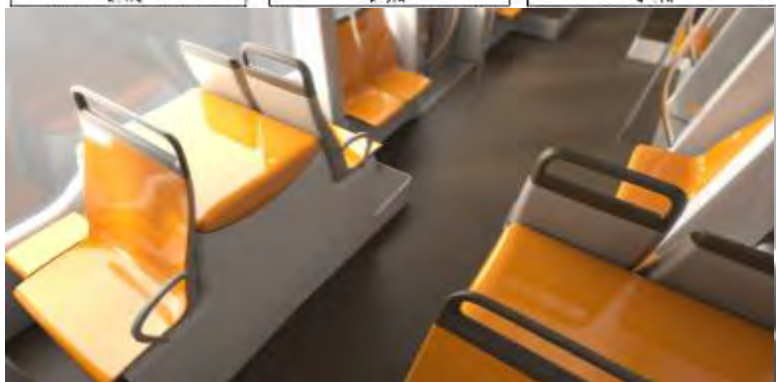
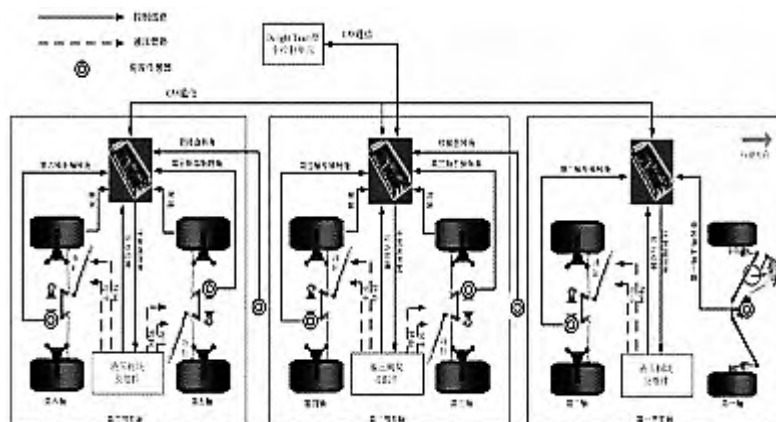

Dispatching Management System 调度管理系统

Onboard System 车载系统

Crossing Priority Control System 十字路口优先控制系统

- Operation monitor
操作监控
- Emergency management
紧急情况管理
- Equipment monitor
设备监控
- Operation and maintenance
运行维护
- CLK、CCTV、PA interface
CLK, CCTV, PA 接口

- Over speed alarm
超速警报
- Vehicle-ground communication
车地通信
- Operate remind
运营提醒
- Drive record
驾驶记录

- Traffic signal controller interface
交通信号控制接口
- Vehicle-ground communication
车地通信
- Priority requirement management
优先需求管理

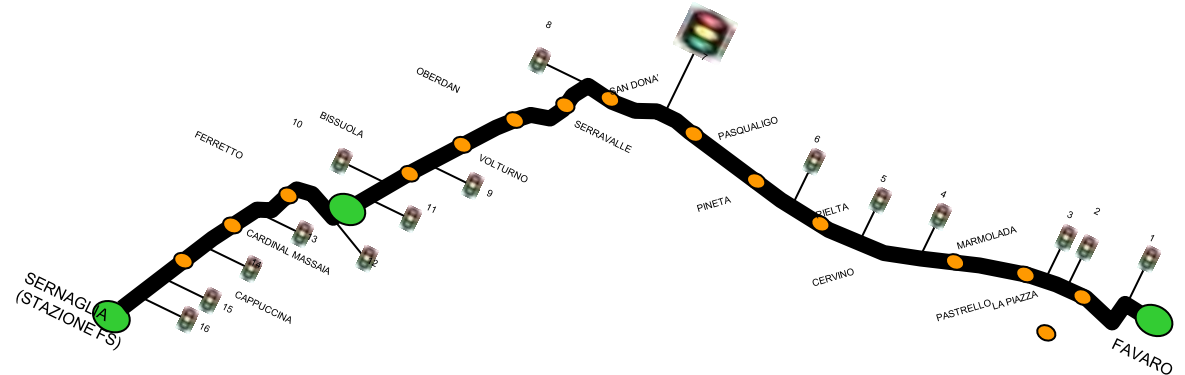

3. ADVANTAGES 优势比较



ART is the ideal solution for 下列情况下是理想的解决方案：

- supplement to rail transit in the metropolis
大城市的轨道交通的补充
- public transportation or small and medium cities
中小城市客运系统的主要解决方案
- urban or suburban public transportation and touring transport in specific sightseeing districts
做为城市或郊区公共客运交通和特定旅游区的游客运输的主要解决方案

SHORT CONSTRUCTION TIME 建设周期短



Project 项目	1 month	2 month	3 month	4 month	5 month	6 month	7 month	8 month	9 month	10 month	11 month	12 month
Plan 计划	Active	Active	Completed	Completed	Completed	Completed	Completed	Completed	Completed	Completed	Completed	Completed
Approval 批准	Completed	Completed	Active	Completed	Completed	Completed	Completed	Completed	Completed	Completed	Completed	Completed
Station Construction 车站建设	Completed	Completed	Active	Active	Active	Active	Active	Completed	Completed	Completed	Completed	Completed
Tram Manufactory 车辆制造	Completed	Completed	Completed	Active	Active	Active	Active	Completed	Completed	Completed	Completed	Completed
Inspection Center Construction 检测中心建设	Completed	Completed	Completed	Active	Active	Active	Active	Completed	Completed	Completed	Completed	Completed
Operation Test 运营测试	Completed	Completed	Completed	Completed	Completed	Completed	Active	Active	Active	Completed	Completed	Completed
Formal Operation 试运营	Completed	Completed	Completed	Completed	Completed	Completed	Completed	Completed	Completed	Active	Active	Active



modular design or ad ustable combination 模块化设计，按客流量随时调节编组

various right-of-way styles 多种路权形式

Right-of-Way
路权

Exclusive 单独路权
(A class)

Part-Exclusive 部分路权
(B class)

Share 共有路权
(C class)

ample
示例



various station styles 多种车站形式

Station
车站

Island Station
岛状车站

Hermetic Station
封闭式车站

Open Station
开放式车站

ample
示例



- simple maintenance, and smaller depot
维修简单，站务小巧
- smaller depot, Simple inspection, numerous maintain equipment is unnecessary
站务小巧，检测简单，无需繁杂的维修设备。

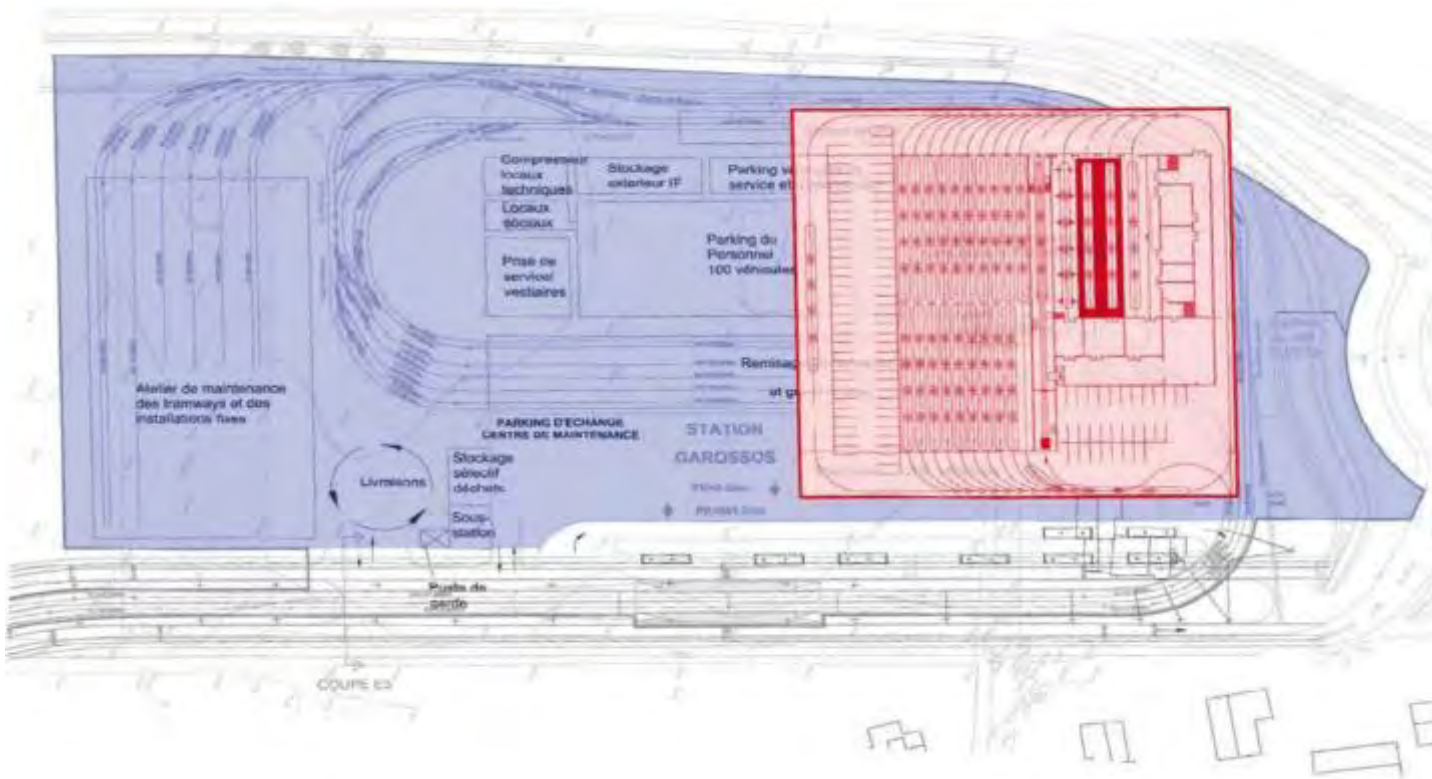

 Traditional tramcar
传统电车 (25000 m²)

 ART (< 10000 m²) can also share with the bus parking
可和其他公共汽车共用停车场

COST COMPARISON (AUD) 成本比较



80 1 0
million m
0.8 1. 亿公里

Subway
地铁



30 0
million m
0.3 0. 亿公里

Traditional Tramcar
传统电车



20 30
million m
0.2 0.3亿公里

Translohr
劳尔电车



6 8
million m
0.06 0.08千万公里

ART



Technology
Experience
Capability

C. Questionnaire - Siemens

Réf. : RC-FR_MO_MM_OPTG/OBOAR/51.0042.18/DMD/DMD 0001 00 EN
Ed/Rév : 01/00
Traduction : EN
Diffusion : Choisissez un élément.
Mémo : 1079497
Date : 13/12/18

Projet / Project

A428 corridor from Cambridge
to Cambourne

Arborescence / Technical number**Type de document / Type of document**

QUESTIONNAIRE

TITRE / TITLE

ALTERNATIVE GUIDANCE OPTIONS ASSESSMENT

Mots clés descripteurs / Descriptors**Rédacteur / Author**

D. MARCHAND

Nombre de pages / Number of pages

20

APPROBATION / APPROVAL

Nom / Name	Fonction / Function	Signature / Signature
Denis Marchand	Optiboard Business Manager	

SUIVI D'ÉVOLUTIONS / REVISION RECORDS

Edition / Révision <i>Version number</i>	Date <i>Date</i>	§ concernés <i>Affected §</i>	Modification <i>Change</i>	Justification <i>Justification</i>
01/00	13/12/18			Creation

SOMMAIRE

1. INTRODUCTION	4
1.1. BRIEF	4
1.2. PURPOSE	4
2. MARKET SOUNDING QUESTIONNAIRE.....	5
2.1. PROVEN PASSENGER OPERATION.....	5
2.2. TECHNOLOGY	9
2.3. MAINTENANCE	13
2.4. INFRASTRUCTURE	14
2.5. COSTS	15
2.6. SAFETY.....	16
2.7. PASSENGER FEEDBACK	18
2.8. DRIVER FEEDBACK	19
FIN DU DOCUMENT.....	20

1. INTRODUCTION

1.1. Brief

The Greater Cambridge Partnership are developing proposals for a transport scheme along the A428 corridor from Cambridge to Cambourne. Consultation on the scheme, including alignment and mode are on-going. As part of the development of those proposals, and without prejudice to any further consultations and decisions, the Greater Cambridge Partnership are looking at providing the necessary infrastructure, to deploy rubber-tyred passenger transport vehicles with guidance system technology (excluding kerb guidance).

The vehicle guidance system needs to have the capability to provide guidance both whilst aligning with the kerb / platform at passenger stops and when traveling between stops. The steering control element of the guidance system should be operable with or without direct intervention of the driver. Whilst the guidance system is active, the driver should only be required to control the longitudinal motion (acceleration/deceleration) of the vehicle, including the option to override the guidance system through deliberate action if deemed necessary.

To summarise, the driver should retain full control of the following aspects during system engagement:

- Control of longitudinal motions.
- Monitoring of the driving environment.
- Fall back performance of vehicle steering control.

1.2. Purpose

The purpose of the market sounding questionnaire is to enable the Greater Cambridge Partnership to gain a better understanding of the options and capabilities of the vehicle guidance systems available in order to inform the development of the proposals. The questionnaire is intended for both suppliers of guidance systems and vehicle manufacturers integrating guidance technologies into their vehicles.

2. MARKET SOUNDING QUESTIONNAIRE

2.1. Proven Passenger Operation

2.1.1.

Please provide information, in the form of the following table, detailing examples of the guidance system in proven passenger operation:

City	Nb of Years	Network Length	Platforms	Nb of Buses	Status
Rouen	18	30 km	100	85	Operation
Castellon	10	10 km	30	10	Operation
Nimes	7	4 km	22	13	Operation

Rouen - "TEOR, Transport Est Ouest Rouennais" network consisted of 3 lines, mainly on a dedicated lane, with 52 stations fitted out for optical guidance and 30 km laid out. The fleet comprises 69 guided vehicles. Commercial operation started in 2001.

Since it was put into service, the amount of people using the TEOR has grown considerably. Passengers have awarded a "Quality" rating of 16.2 / 20 to the TEOR system (for comparison purposes, the tramway obtained 15.7 / 20).

As well as proving popular with passengers, the optical guidance system is also praised by the drivers:

- 100 % of the drivers consider the system as useful;
- Over 80 % of drivers feel more available, more cautious and less stressed.

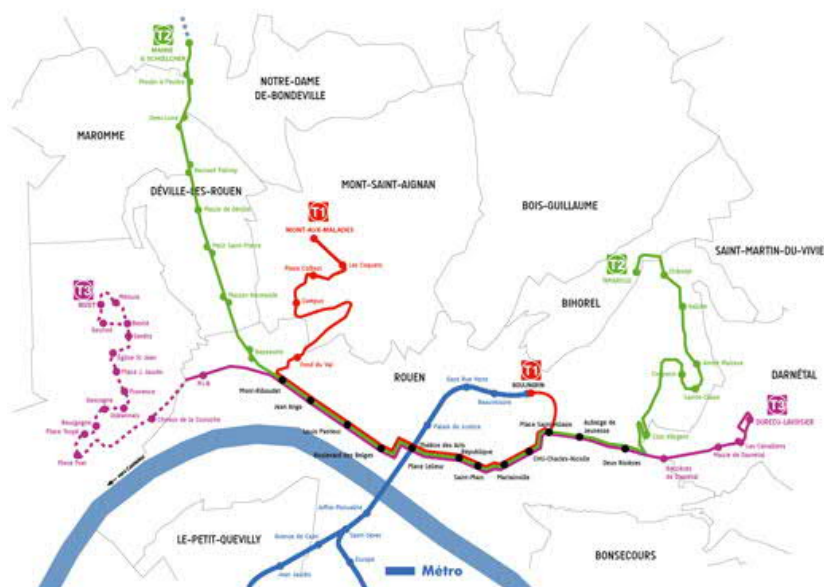

Mont-Saint-Aignan / Boulingrin

La ligne T1 passe par le centre-ville de Rouen, le Mont-Riboudet, l'allée du Fond du val, le Campus Universitaire et enfin le quartier de la chaufferie à Mont-Saint-Aignan.



Notre-Dame-de-Bondeville / Hauts de Rouen

Cette ligne dessert la Vallée du Cailly et traverse 5 communes (Notre-Dame-de-Bondeville, Maromme, Déville lès Rouen, Rouen et Bihorel) pour rejoindre les Hauts de Rouen.



Canteleu / Darnétal

En site protégé à partir des Barrières du Havre, la ligne dessert le centre de Darnétal pour rejoindre l'hôpital Durécu-Lavoisier.

Castellon de la Plana - The Valence province commercially operates a continuous guidance section at Castellon de la Plana (June 2008). An extension is in operations since 2014.



Nimes - For its 1st BRT line, Nîmes Métropole chose the Optiguide guidance system. With a length of 4km and eleven 18m vehicles, commercial operation started in September of 2012.

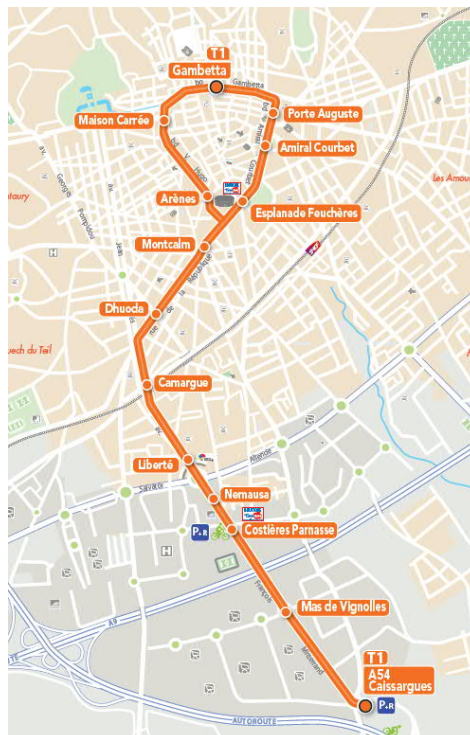

Tokio - Within the « Hydrogen Society » program, a semi Autonomous bus system using Optiboard is in test on an heterogenous fleet (12 et 18m) from 2 bus suppliers. Commercial operation expected mid 2020.

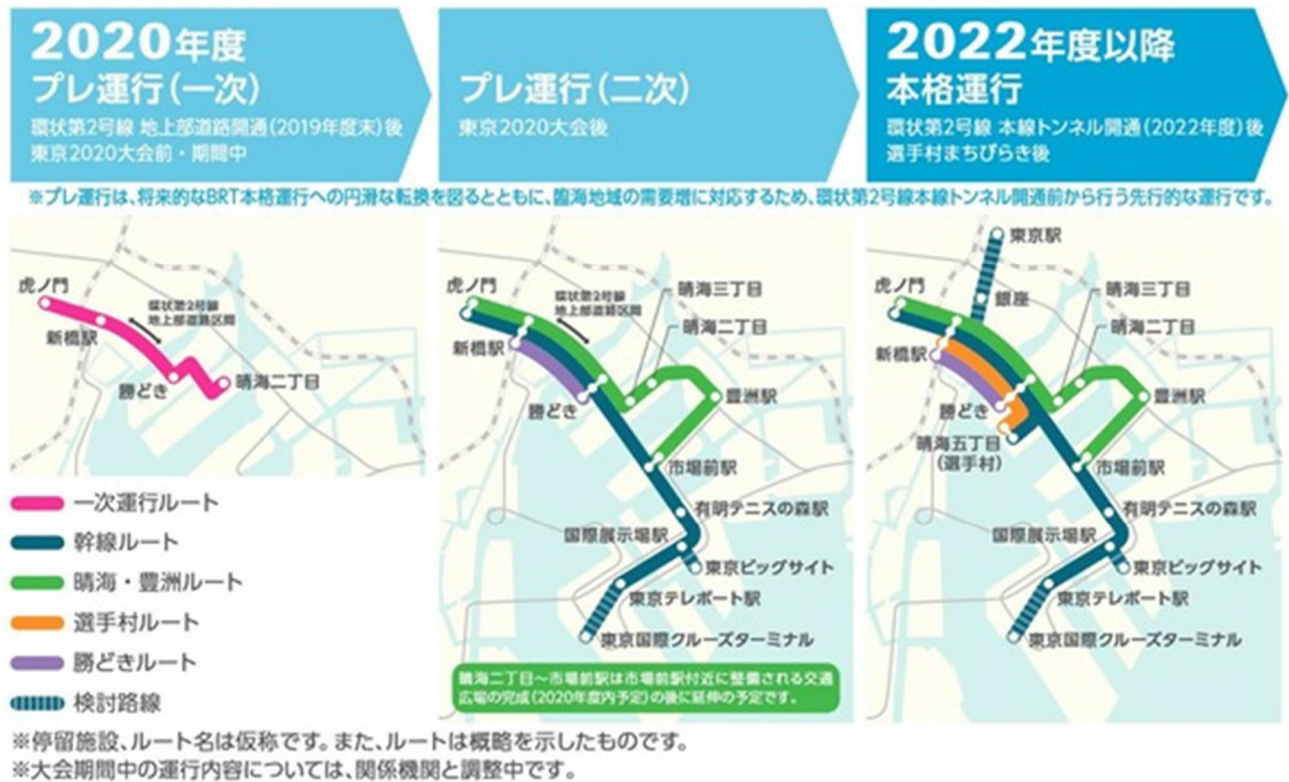

2.1.4.

For guidance systems with orders received and without proven passenger operation, details should be provided as to how the supplier would gain approval for the guidance system to be used in the UK.

No experience in UK, the system does not enter into a specific approval scheme In France, Spain, Italy, Spain & Japan.

2.1.5.

For guidance systems currently under development and without proven passenger operation, details should be provided as to how the supplier would gain vehicle type approval for the guidance system to be used in the UK.

2.1.6.

If applicable, details should be provided as to any issues experienced in passenger operation using the guidance system.

2.2. Technology

2.2.1.

Briefly state how the guidance system works.

Optiboard ECU analyzes the image recorded by the **CAMERA** located at the front of the vehicle. It identifies the ground markings, calculates the lane geometry data (curve radius, straight section, etc...) and measures the lateral position and orientation of the vehicle in relation to the marked trajectory. It achieves this by completing the data from the image analysis with the vehicle yaw speed.

The characteristics related to the vehicle are taken into account in the form of parameters that are stored in the ECU: position and field of the camera, vehicle characteristics.

ECU produces the instruction to be applied, using the kinematic data from the vehicle's estimation module. Dynamic vehicle behavior models are used to calculate this instruction to make the vehicle follow the best possible trajectory by considering:

- The vehicle's maneuvering capabilities;
- The limits imposed by the criteria concerning passenger comfort and driver acceptance;
- The present status and the predictable future status.

The markings on the road surface are laid out by considering the gauge of the vehicle and its maneuvering capabilities.

A motor fitted on the vehicle steering column.

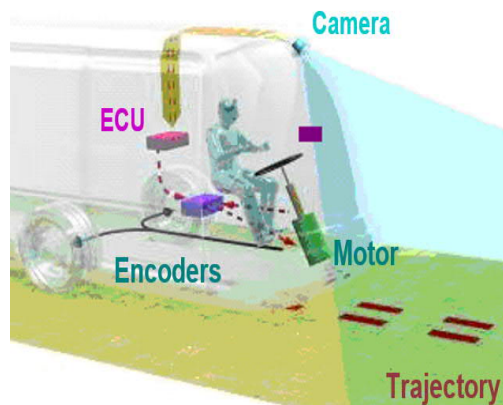

2.2.2.

The benefits of the guidance system should be detailed in respect to:

- i. Non-guided systems
 - **Optiboard** provides **optimized accessibility** thanks to very precise and repeatable lateral positioning of the vehicle alongside the platform. It facilitates access for people with impaired mobility, people with pushchairs and more generally, all passengers. This lateral docking quality reduces the vertical gap ("step") and avoids the risk of collision between the vehicle and the platform. Passenger exchange times in the station are reduced, which improves commercial speed and therefore, reduces operating costs.
 - **Optiboard** optimizes **lateral comfort** through an adapted layout (clothoid curves, etc.). Vehicle movements perceived by passengers are considerably attenuated, especially in curves and during delicate station approach and departure phases.

- In the context of an electric vehicle, **Optiboard** can position the vehicle to be powered in line or in station.
 - **Optiboard** alleviates driver workload in station approach and departure phases for 12, 18 and 24-m long vehicles.
 - **Optiboard** provides substantial flexibility for both transport system implementation and operation. It is also suitable for combined High/Low Platform operations and for a mixed fleet of vehicles (Several types/manufacturers) with possible "retrofitting" on the existing fleet.
 - **Optiboard** can also produce operating reports that can be used to measure the quality of the proposed service.
 - The ground markings may also be used to implement additional features. The system allows a comparison between speed and speed limit or refers to a braking trigger for soft docking brake. This data may be used as a trigger for all functions requiring vehicle position on tracks. More generally, it is possible to warn the driver on a specific control
 - The innovative and "high-tech" nature contributes to the modernity expressed by the transport system, leading to an affordable and operational semi-autonomous bus system.
- ii. Other forms of guided systems
- The nature of optical guidance (no mobile mechanical parts) ensures higher operating flexibility
 - assisted zones are entered and exited "on the fly" without any discontinuity in operation or reduction in performance : using the image obtained by the camera, the system detects the ground markings and analyzes the trajectory.
 - the driver always has complete freedom on driving the vehicle. Assistance is restored automatically without any discontinuity, as soon as the driver has positioned the vehicle correctly relative to the ground markings. The optical assistance system continuously calculates the attitude of the vehicle in relation to these markings (lateral deviation and yaw angle).
 - No system failure requires intervention on the line. The planned procedure consists of continuing operation in manual mode and then replacing the defective component once the vehicle has completed its service.
 - A component failure never prevents operation in manual driving mode.

2.2.3.

Is it possible to disable the guidance system to allow for the vehicle to operate on street in mixed traffic, with the driver taking full control of the vehicle?

A vehicle running on a lane can use either one of the two possible driving modes (assisted or manual) depending on the site configurations and the guidance means available on the infrastructure.

2.2.4.

Does the guidance technology work for both aligning with the kerb / platform at passenger stops and when travelling between stops?

The system may also be used in continuous guidance for Semi-autonomous Operations. The infrastructure at stopping points and in particular the trajectory marked on the ground is defined and adapted to targeted goals: reduced gap in stations, comfort of vehicle movements for passengers.

2.2.5.

Guidance technology suppliers should detail whether their system can be retrofitted onto existing vehicles or whether the system requires custom vehicles to be built.

It is also suitable for combined High/Low Platform operations and for a mixed fleet of vehicles (Several types/manufacturers) with possible "retrofitting" on the existing fleet. The optical guidance system is operational on different types of buses, with a length of 12, 18 but also bi-articulated vehicle.

2.2.6.

If the guidance technology requires custom vehicles, the supplier should list which manufacturers' vehicles the system has been integrated with.

2.2.7.

If available, the following performance parameters should be provided for the guidance technology:

- Operational speeds

The maximum speed during start of guidance is approximately 40 kph.

The maximum speed during guidance is approximately 70 kph.

- Minimum turning radius

The overall performance depends on infrastructure and technical specifications. The overhang and position of the vision system impact the minimal possible turning radius. One site is showing turning radius of 18m.

2.2.8.

What is the proven passenger operation docking and continuous running reliability of the system in terms of how often the driver must correct the vehicle trajectory and make corrections when aligning with the kerb / platform at passenger stops?

1,13 default for 10 000 docking in 2012 at Rouen.

2.2.9.

Are there any operational limitations for the guidance system to be used during adverse weather conditions, such as snow, fog and heavy rain?

If there is a snowfall, the snow must be superficially cleared from the lane in the same way as for any road. The following view is an example of assistance in snowy weather conditions.



2.2.10.

What effect does debris and leaves have on the operation of the guidance system?

The driver receives driving Assistance and **Optiboard** records deteriorations in trajectory vision. In these conditions, the system enters "**Assisted with Vigilance**" mode where HMI is flashing Green & Orange.

If the markings are lost (end of guided zone or marking reading failure), the system enters **Authorized** mode in order to be able to automatically switch back to **Assisted** mode as soon as the required conditions will be complied with.

2.2.11.

For guidance technology suppliers, are there maximum vehicle dimensions (lengths,widths and heights) that the guidance technology will work with?

The system is operational on different types of buses with a length of 12, 18 & 24m. No limit in terms of widths and heights ...

2.2.12.

For vehicle manufacturers with vehicles incorporating guidance technology, what are the maximum vehicle dimensions (lengths, widths and heights)?

2.3. Maintenance

2.3.1.

What are the maintenance requirements of the guidance system?

In each self-test sequence, if an anomaly is detected, the system switches to safety mode and saves the diagnostics in non-volatile memory. During operation, any diagnostic that leads to safety mode is saved in memory. The ECU records the vehicle speed, the system states, the measured curvature of the trajectory and information concerning the man-machine interface (indicators and buzzer).

These data may:

- Facilitate early detection of infrastructure problems (in particular, the road surface), vehicle interface problems or hardware failures of the equipment before they affect availability.
- Provide information on KPI for the operator.

2.3.2.

Will the parts used for the guidance system be readily available?

15 years after delivery.

2.3.3.

Will the guidance system require any special maintenance tooling?

A diagnostic socket located in the driver's cab area is used to connect a maintenance computer to the ECU.

This equipment can be used to carry out operations to identify the defective component. Preventive or corrective maintenance operations are performed by standard replacement of equipments on the vehicle.

2.3.4.

What are the software maintenance requirements of the system?

After replacing a component or after carrying out work on the vehicle that is likely to affect the adjustment of an item of equipment in the system, a calibration operation and a docking test must be carried out.

2.3.5.

How are software updates controlled and managed?

Change management is based on IBM Rational ClearQuest and software configuration management is using IBM Rational ClearCase.

2.4. Infrastructure

2.4.1.

What are the associated infrastructure requirements for the operation of the guidance technology?

The basic infrastructure required for Optiboard® is ground markings. For reasons related to ease of driving, safety, comfort and vehicle/platform interfaces, the marking layout and the resulting vehicle trajectories must be carefully studied and optimized by considering the general constraints of the line and the positioning of stations. The width of the two dashed lines used for guidance is 450 mm. On either side of this 450-mm wide strip, there must be a 300 mm width without any other markings.

Preference will be given to the color that provides the maximum contrast; White on a dark background, Black on a light background. However, a light shade can be considered even though it may slightly affect dashed line detection.

For an Optimal availability of the system, the contrast between the lane (reflection QdL) and trajectory (reflection QdT) and defined as follows $(QdT-QdL/QdT+QdL)$ should remain around 0.5.

2.4.2.

What infrastructure maintenance does the guidance system require to continue operating safely and accurately?

Availability depends on contrast between guideway and trajectory, there is **no impact on Safety and Accuracy**, which remains a must.

2.4.3.

Are there any guideway dimensional limitations for the guidance technology to operate within?

No particular requirement, similar as manual driving.

2.5. Costs

2.5.1.

Details of the capital costs of the guidance system should be provided including:

- i. The whole vehicle with guidance system; and/or
- ii. Only the guidance System.

The costs depends on the number of units and heterogeneity of the fleet.

For a fleet of 20 units, integrated in eBus of 24m, the unitary price remains under 5% of the eBus' cost.

The costs and all other Commercial issues must handled by Siemens UK without exceptions.

2.6. Safety

2.6.1.

Does the driver have access to an override control, which allows them to regain full control of the vehicle?
[Done using steering wheel \(See 2.6.2\).](#)

2.6.2.

If the driver inputs a steering command to the steering wheel during active guidance, will the steering command override the guidance control?
[Take over by Driver is detected in less than 5ms and the system enters stand by mode.](#)

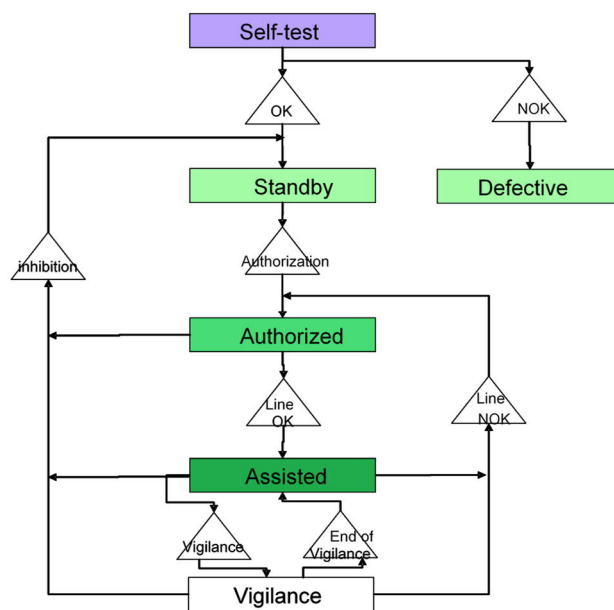

2.6.3.

What other safety features does the guidance system incorporate?
[In French in the text](#)

3.1 RAPPEL DES OBJECTIFS DE SECURITE

L'objectif de sécurité défini par Siemens était le suivant :

La sécurité en conduite assistée par le dispositif OPTIBOARD doit être globalement au moins équivalente (GAME) à la sécurité en conduite non assistée.

Ceci implique que :

- doit être inférieure à 10^{-7} /h/véhicule la probabilité qu'une défaillance du dispositif OPTIBOARD provoque, compte-tenu de la réaction du conducteur, une altération de la trajectoire supérieure à celles qui peuvent être provoquées par des incidents sur le véhicule en conduite non assistée, incidents tels que éclatement de pneu, blocage de roue, panne de la direction assistée (à ne pas confondre avec la conduite assistée).
- en conduite assistée, des perturbations extérieures (telles que rafale de vent violent, devers excessif de la chaussée), ou des incidents sur le véhicule indépendants du dispositif OPTIBOARD, ne doivent pas provoquer une altération de la trajectoire supérieure à ce qu'elle serait en conduite non assistée.
- à tout instant, le conducteur doit pouvoir reprendre la conduite manuelle non assistée pour, par exemple, éviter un obstacle imprévu.

Optiboard system has been subjected to approval that notably validated the expected performance levels. The approval tests were supervised by an approved body according to Regulation No 402/2013.

TÜV SÜD assessment summary

Scope of TÜV SÜD

Independent assessment of the risk management process



Summary

- The safety assurance plan defines the roles and responsibilities of the persons carrying out safety activities
- The safety assurance plan defines the risk management process activities
- The risk management process was carried out according Regulation 402/2013 by the manufactures
- The identified hazards are complete and the defined mitigation measures suitable to reduce the initial risk
- The demonstration of compliance with the safety requirements is acceptable and considered as sufficient

2.7. Passenger Feedback

2.7.1.

What is the view of passengers on the guidance technology?

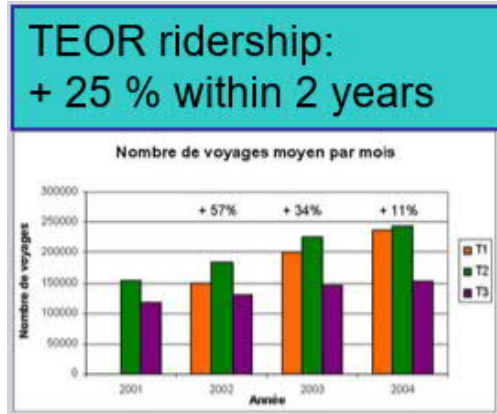

2.7.2.

In particular, do passengers feel safe?

User satisfaction enquiries Rouen Network	
Bus	15.4 / 20
Tram	15.7 / 20
Guided bus	16.2 / 20

2.7.3.

What benefits do passengers think the technology brings?



2.8. Driver Feedback

2.8.1.

What is the view of drivers on the guidance technology?

Drivers enquiry, 2003

- 100% of drivers find the guidance useful
- 83% of drivers feel more available to watch around the vehicle when approaching the station
- 80% feel less stressed

FIN DU DOCUMENT

